

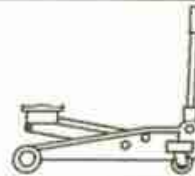

2" LIFT KIT JEEP WRANGLER

www.mopar.com

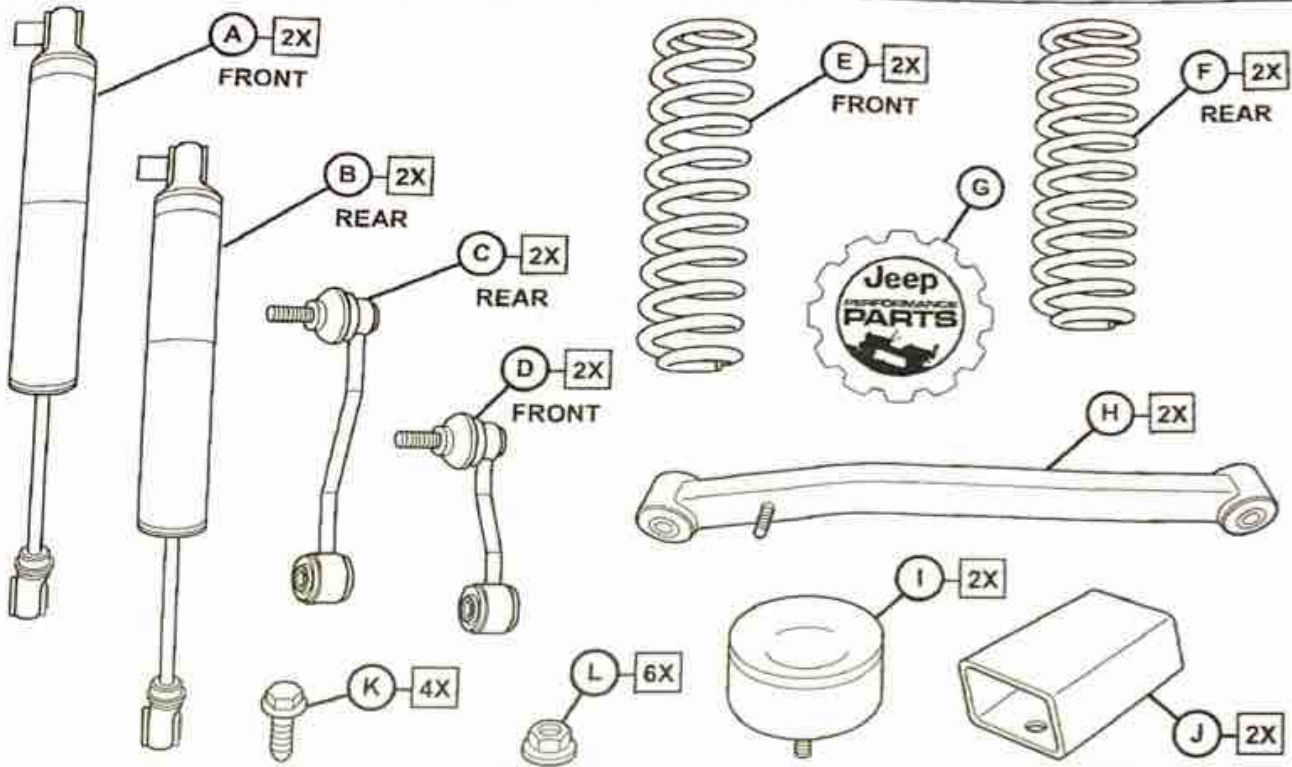

IMPORTANT:

Prior to beginning, inspect the vehicles steering, driveline, and brake systems, paying close attention to the suspension link arms and bushings, stabilizer bars and bushings, tie rod ends, pitman arm, ball joints and wheel bearings.

Also check the steering sector-to-frame and all suspension-to-frame attaching points for stress cracks.

The overall vehicle must be in excellent working condition. Repair or replace all worn parts.











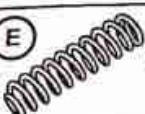
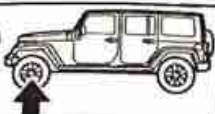
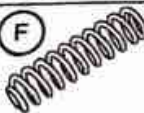
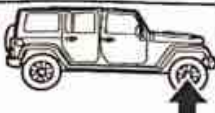

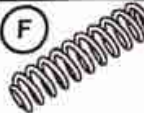



Read instructions several times before starting.

Be sure you have all needed parts and know where they install. Read each step completely as you go.

RETAIN ALL FASTENERS FOR LATER REINSTALLATION.

1

PART REFERENCE

DESCRIPTION	PART NO.	LIFT KIT:				
		3.6L	2.0L	3.6L	2.0L	3.0L
		4 DOOR		2 DOOR		4 DOOR
		77072395	77072430	77072396	77072397	77072399
E  	68414065AA	1 - LF				
F  	68414067AA	1 - RF				
E  	68414066AA	1 - LR	1 - LR			
F  	68414068AA	1 - RR	1 - RR			
E 	68414067AA		2			
	68414069AA			2		
	68414071AA				2	
	68414073AA					2
F 	68414070AA			2		
	68414072AA				2	
	68414074AA					2
A 	68316572AA	2	2			
	68316570AA			2	2	
	68316574AA					2
B 	68316582AA	2	2			
	68316580AA			2	2	
	68316584AA					2
C 	68306981AA	2	2	2	2	2
D 	68306982AA	2	2	2	2	2
I 	68316587AA	2	2	2	2	2
J 	68323933AA	2	2	2	2	2
H 	68322798AA	2	2	2	2	2
L 	6101695	6	6	6	6	6
K 	05143356AC	4	4	4	4	4
G 	82214271	1	1	1	1	1

FRONT DISASSEMBLY

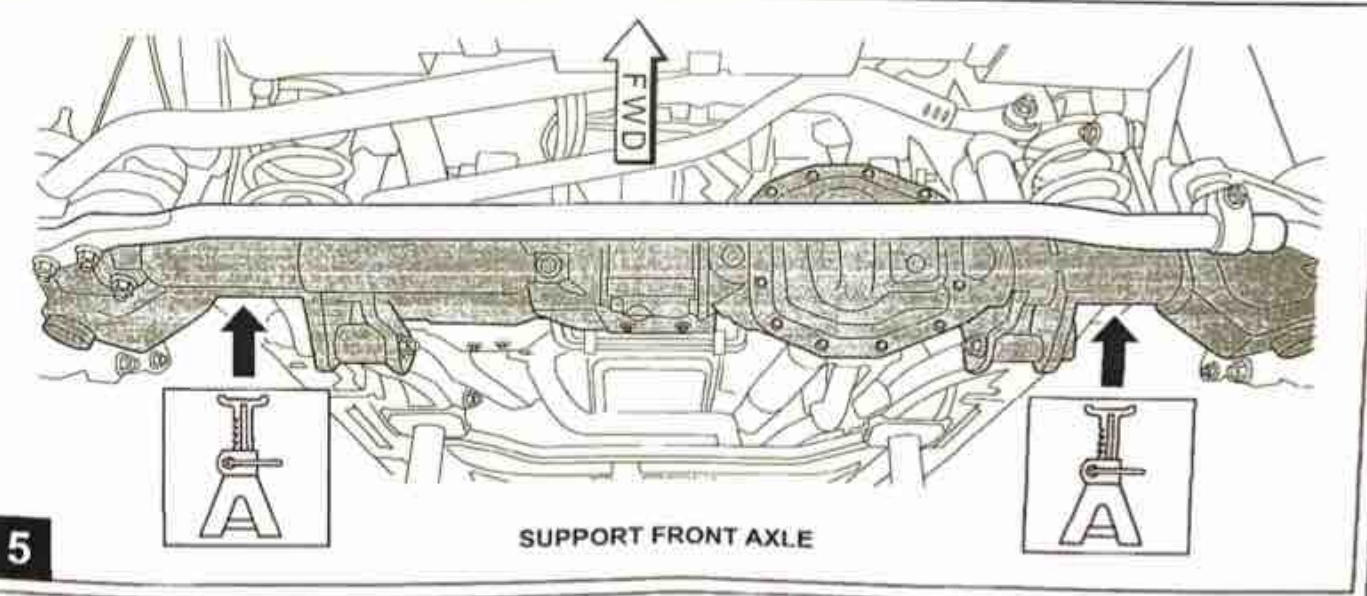
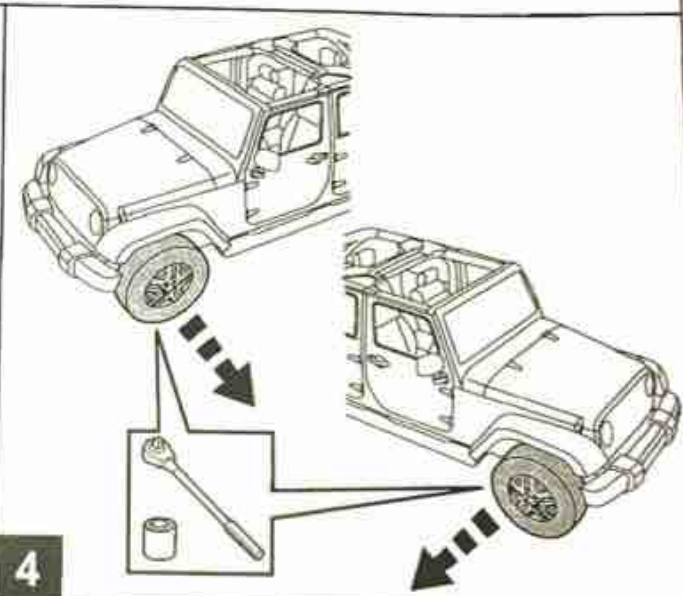
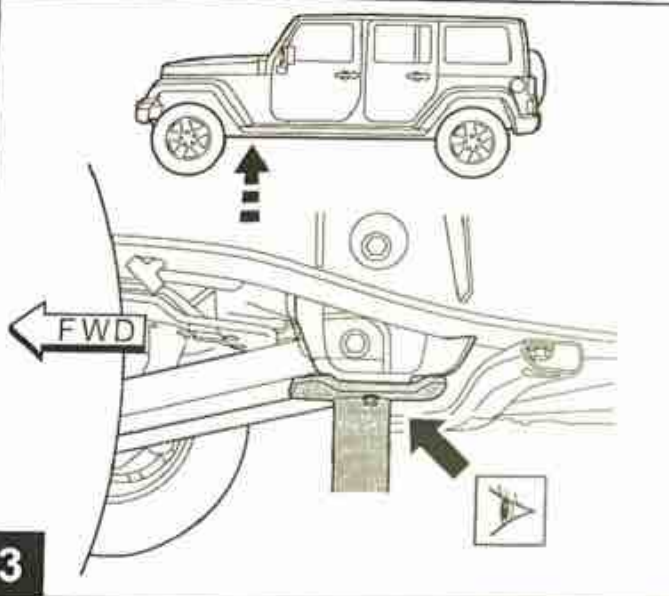
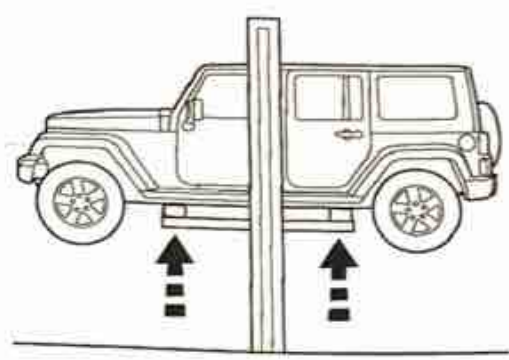
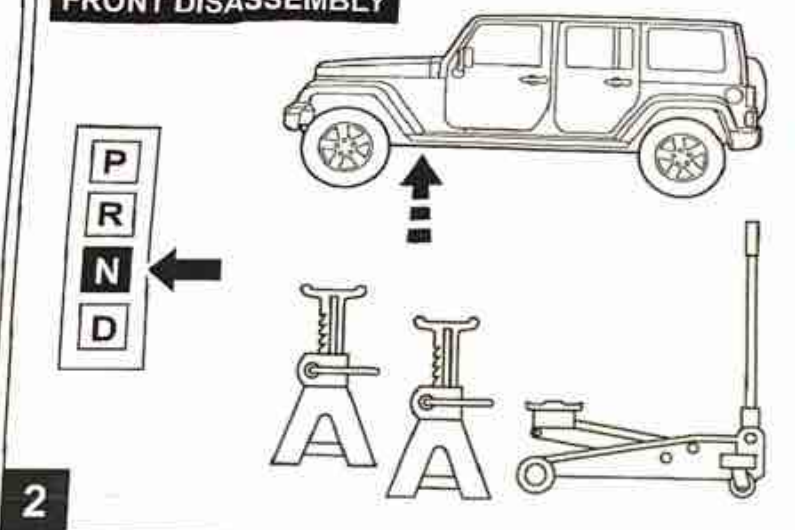

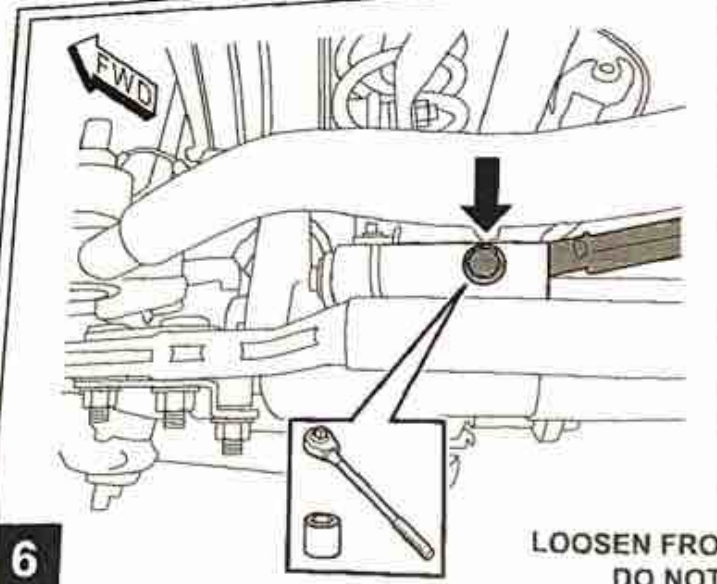

6

LOOSEN FRONT TRACK BAR
DO NOT REMOVE

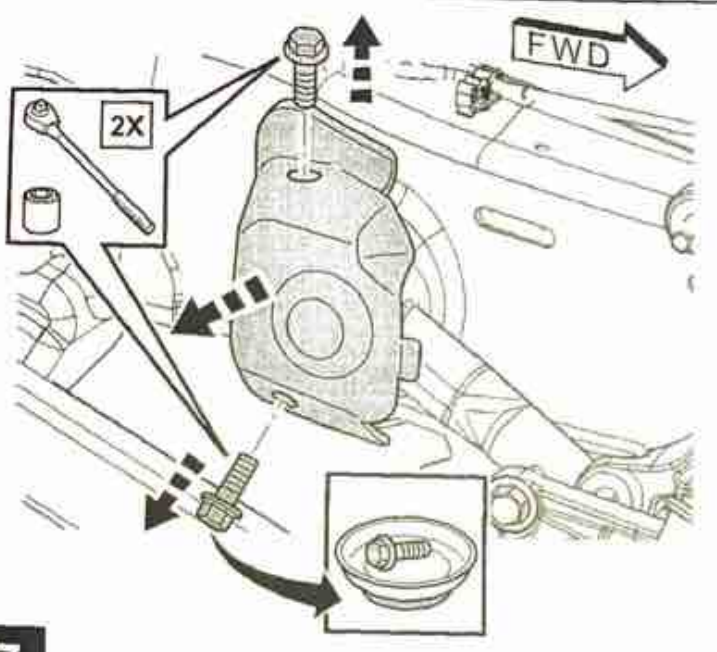

7

REMOVE SHIELD ON BOTH SIDES TO ACCESS UPPER CONTROL ARM BOLTS

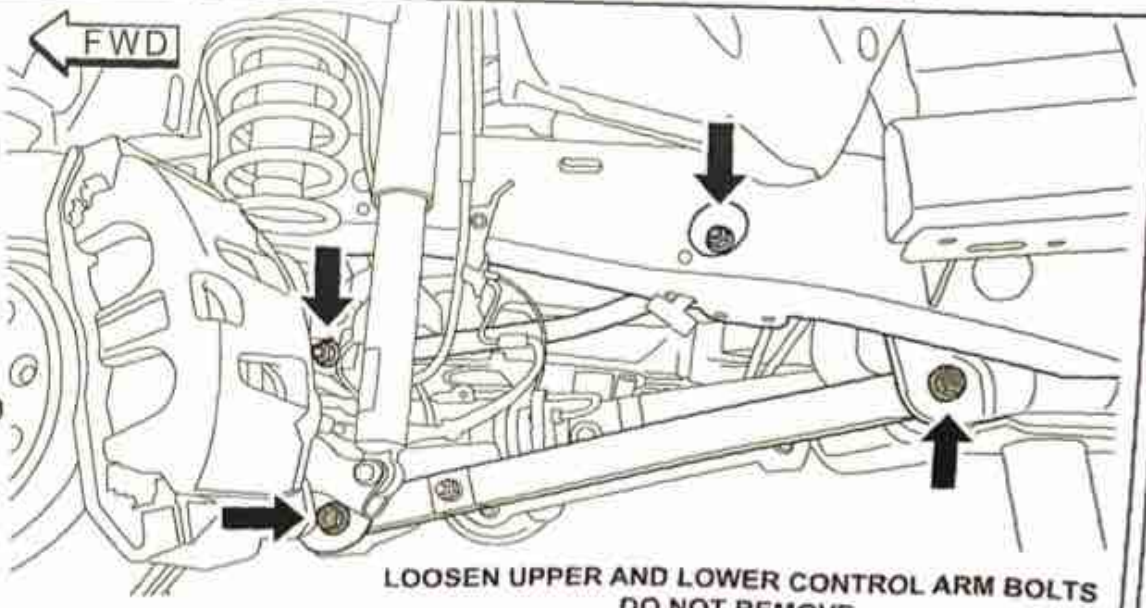
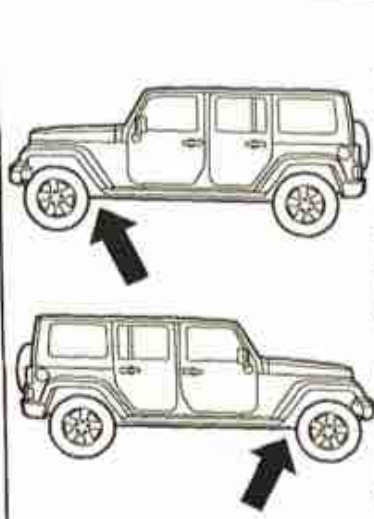
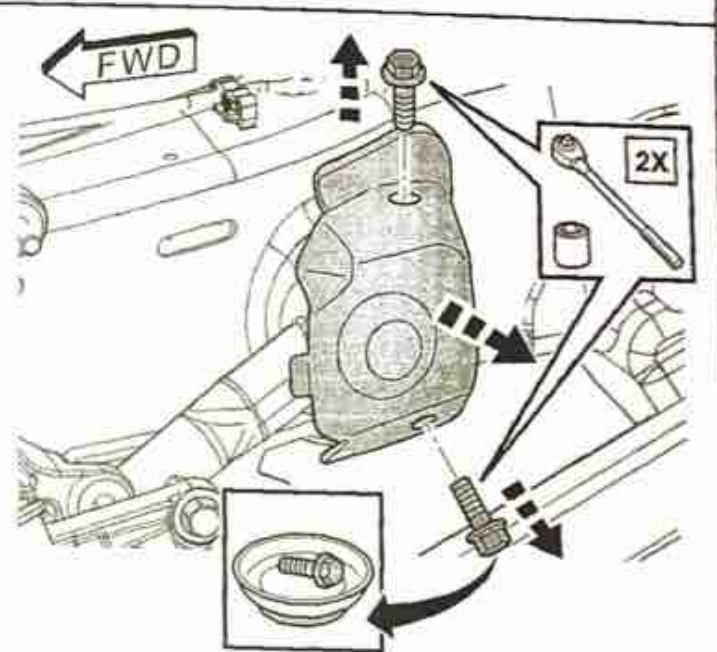

8

2X

LOOSEN UPPER AND LOWER CONTROL ARM BOLTS
DO NOT REMOVE

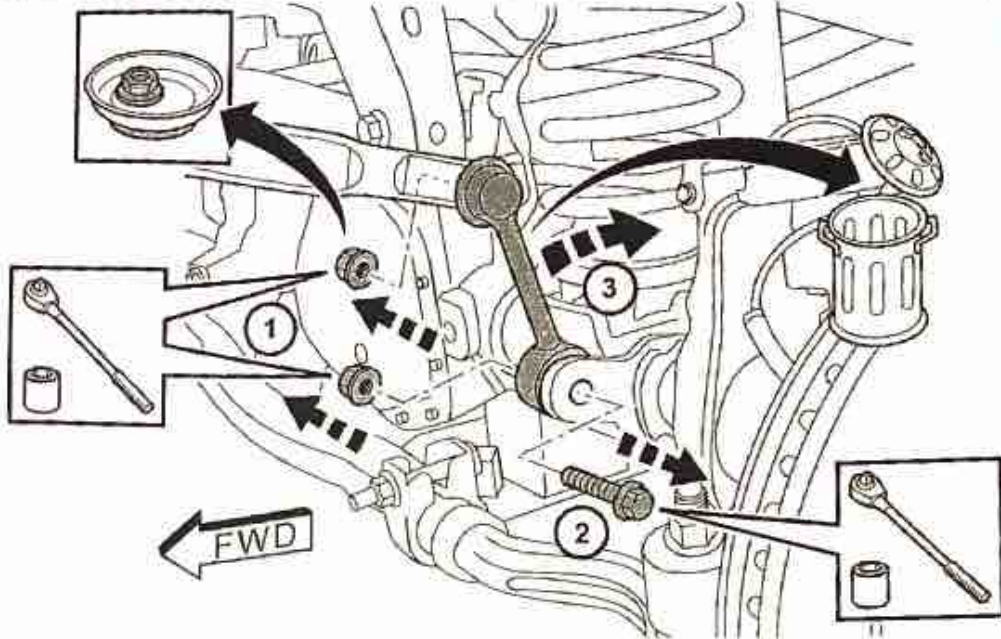
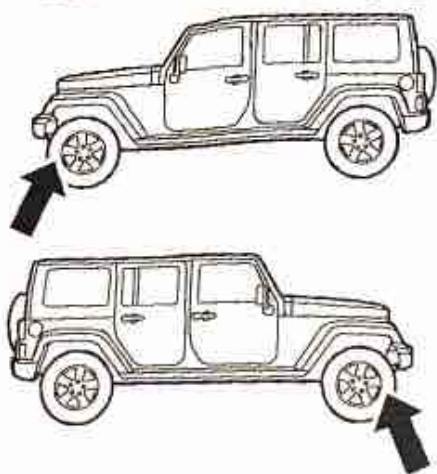

9 2X

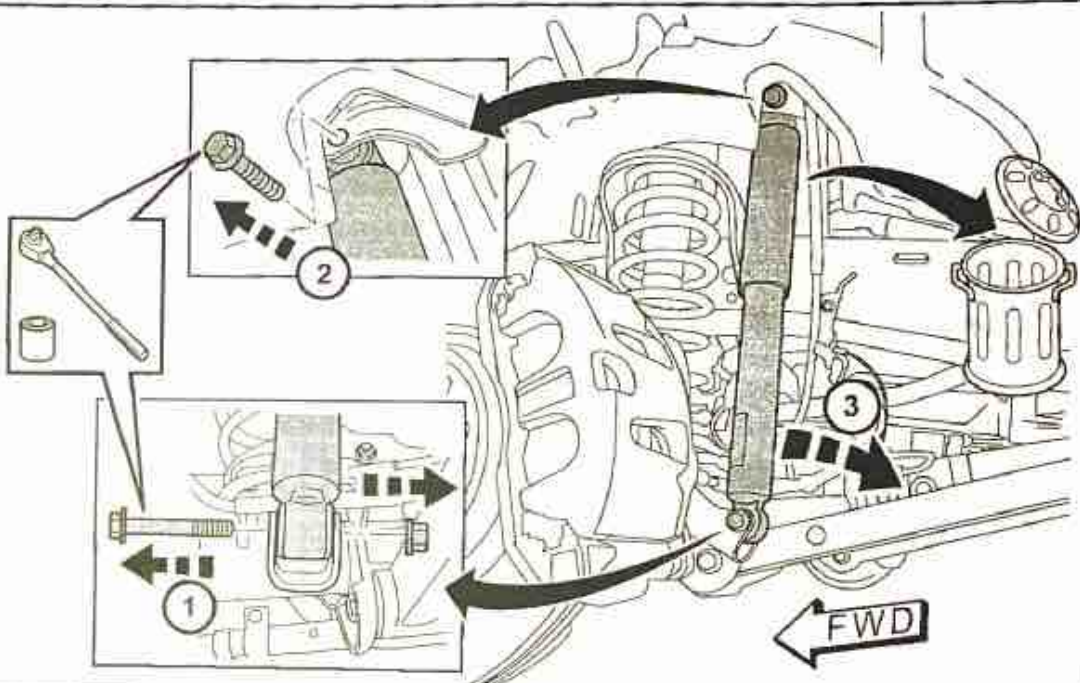
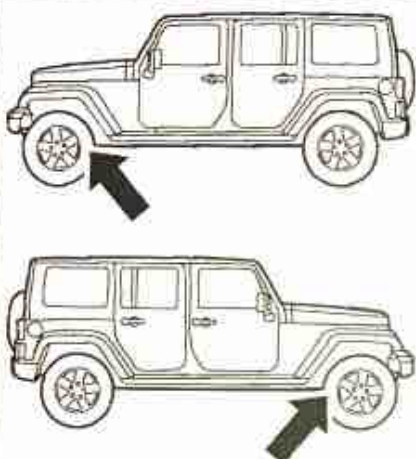

10 2X

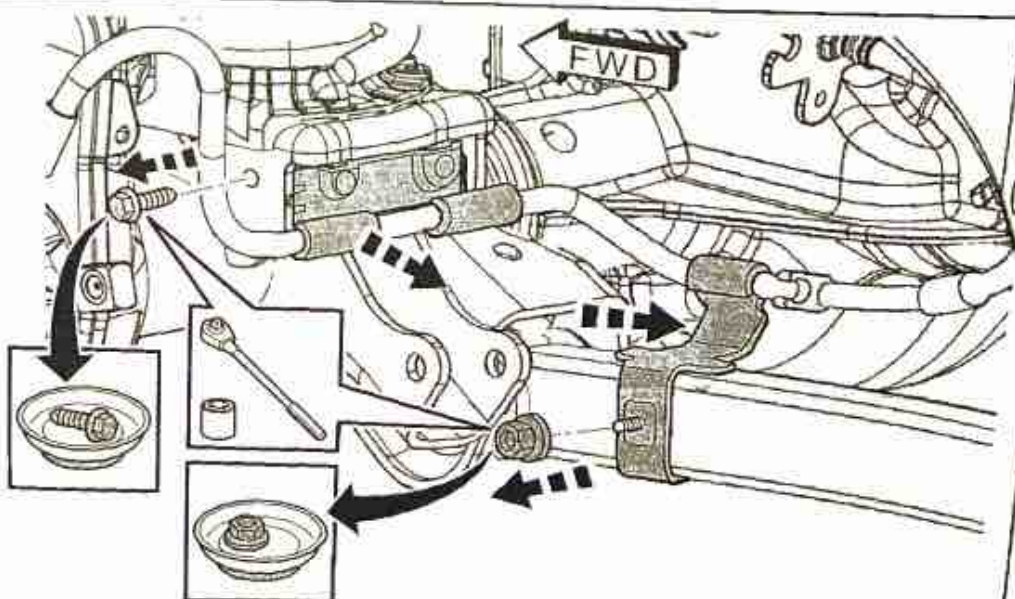
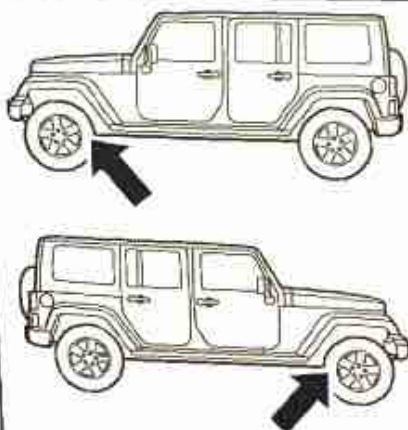

11 2X

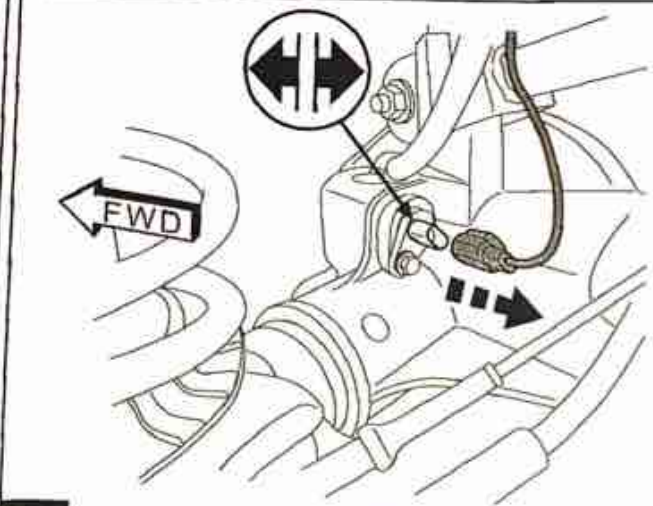

12

DRIVER SIDE

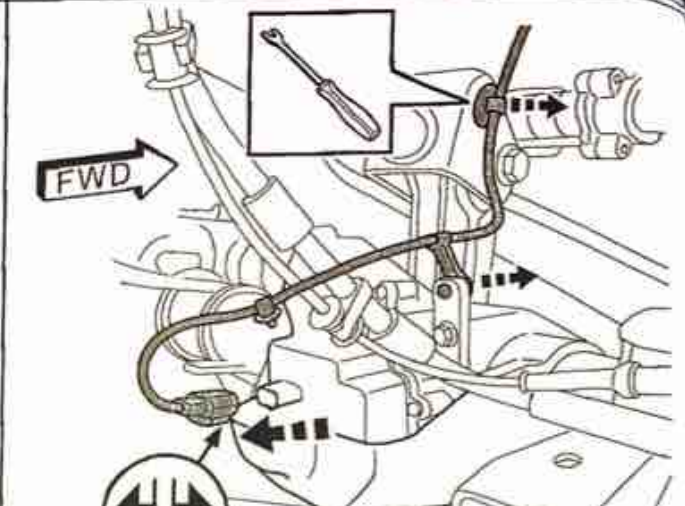

13

PASSENGER SIDE

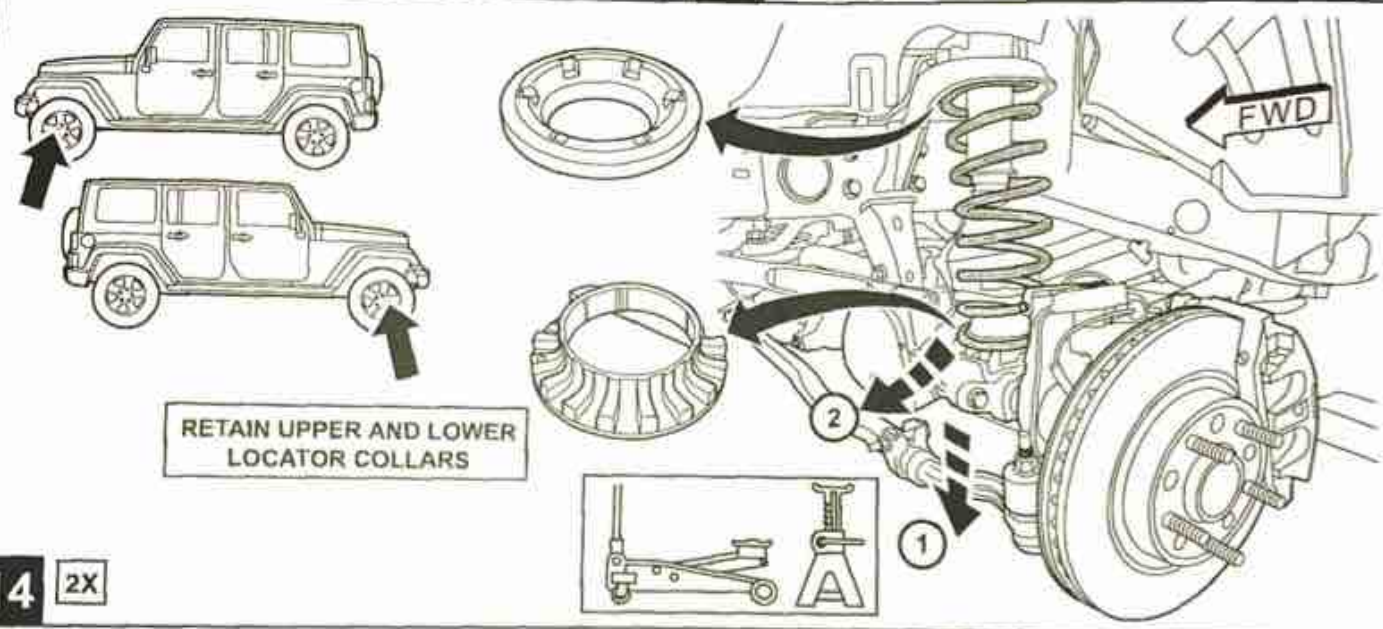

14

2X

RETAIN UPPER AND LOWER LOCATOR COLLARS

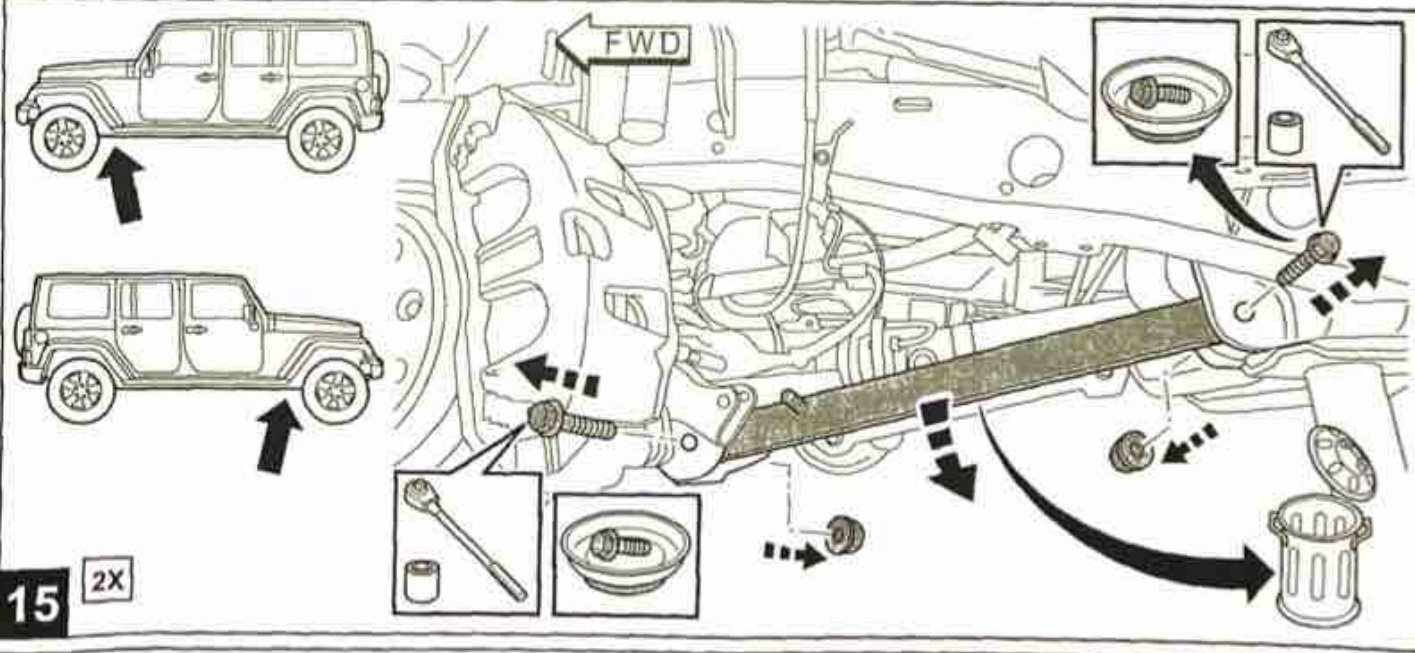

15

2X

FRONT ASSEMBLY

NOTE:

INSTALL NEW KIT COMPONENTS AS SHOWN IN THE FOLLOWING STEPS, BUT DO NOT FULLY TIGHTEN FASTENERS UNTIL INSTRUCTED TO DO SO.

16

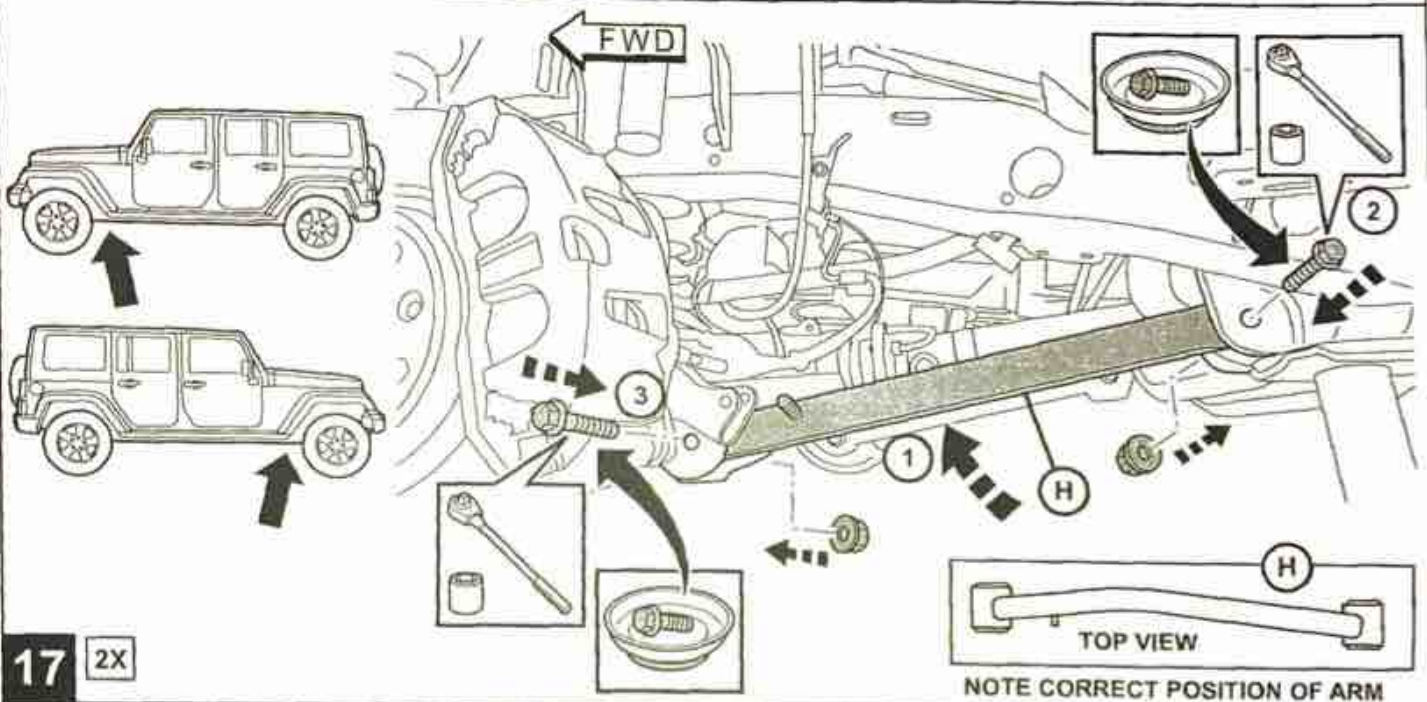

17 2X

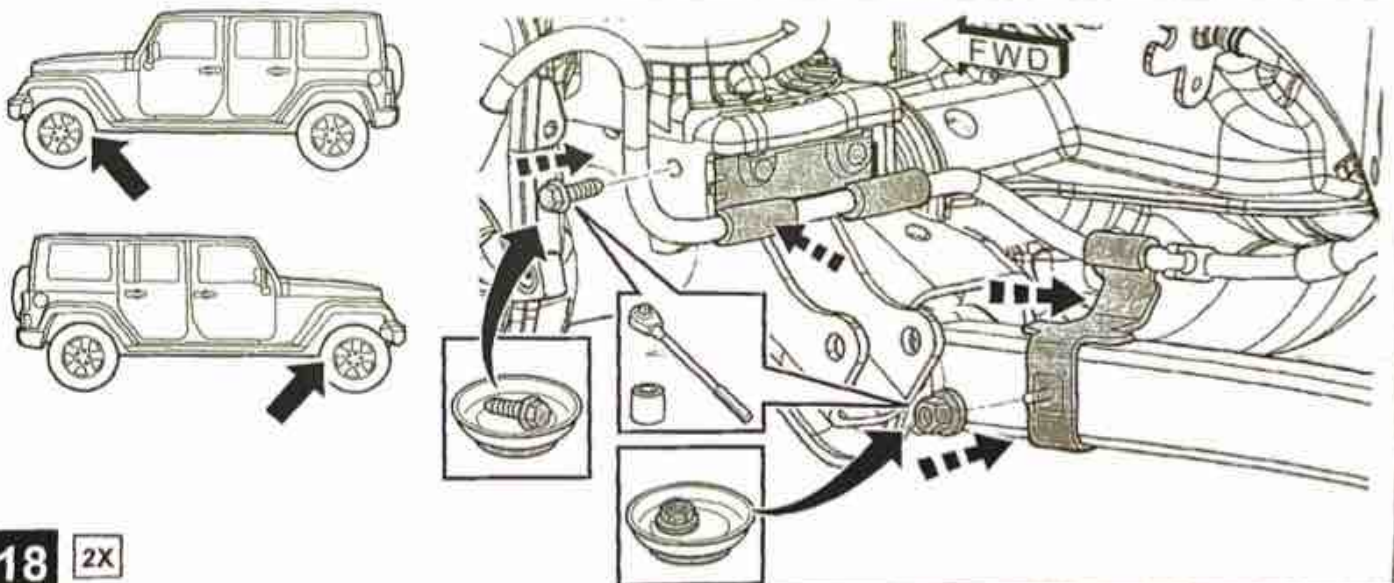

18 2X

Use the new GRAY isolators that are provided in the kit.
The isolators are Labeled with L 68342245 and R, 68342250

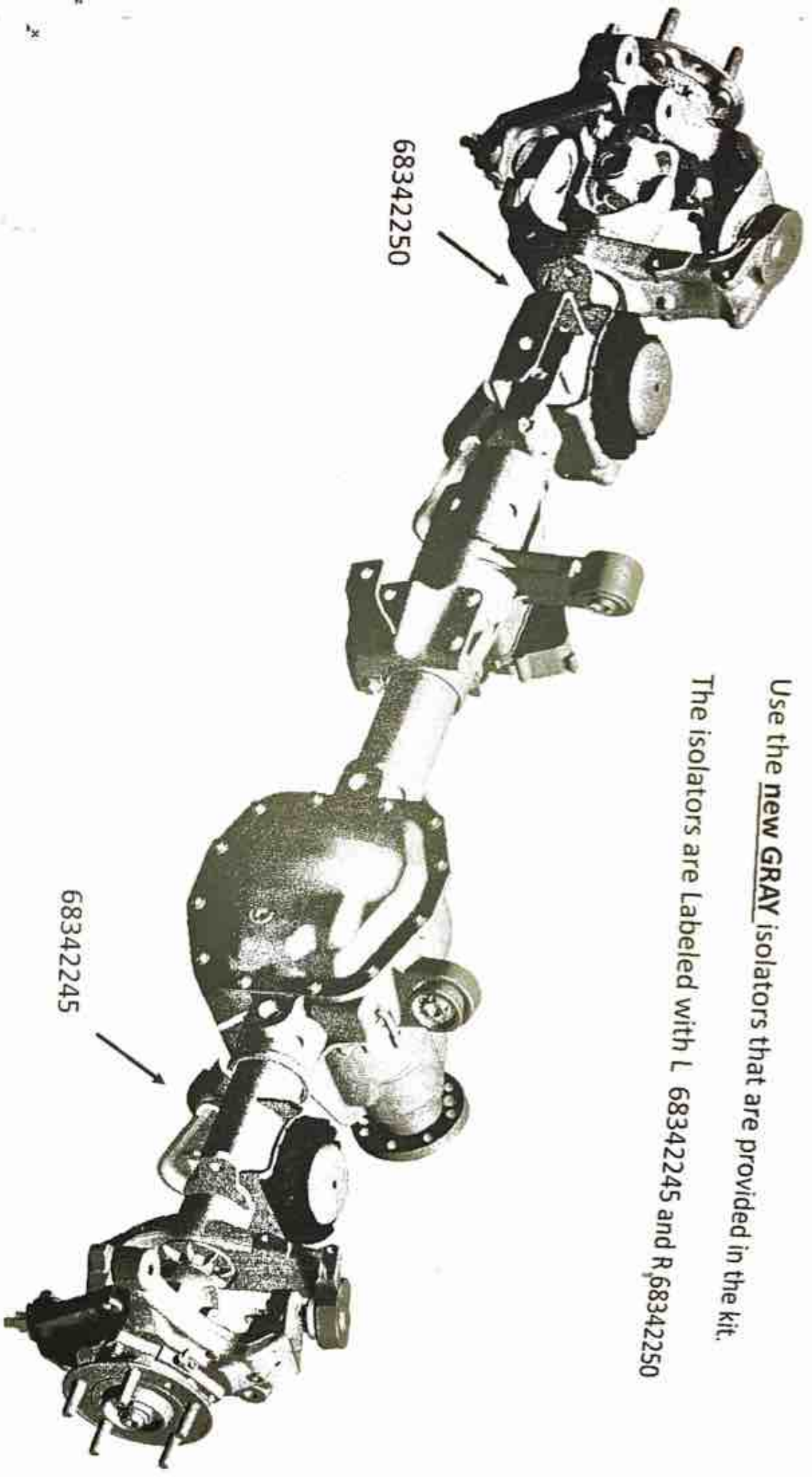

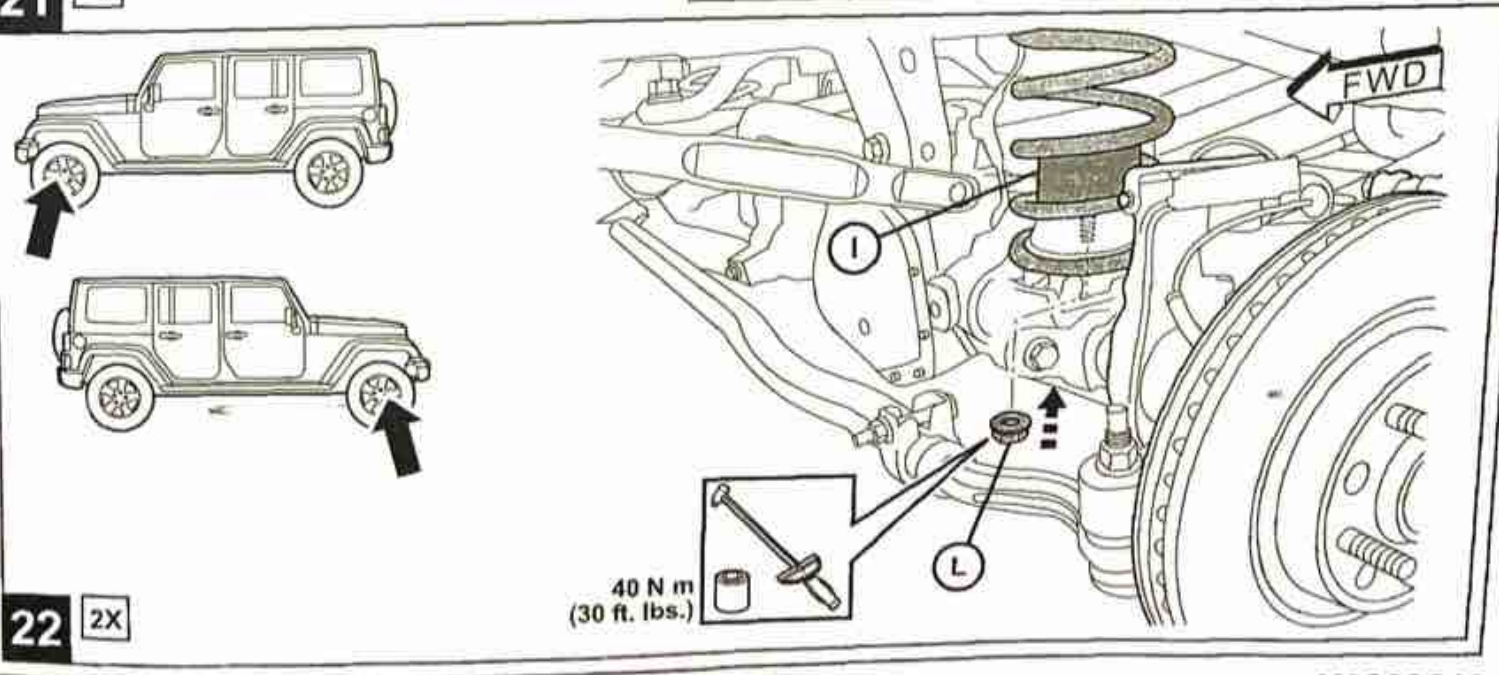
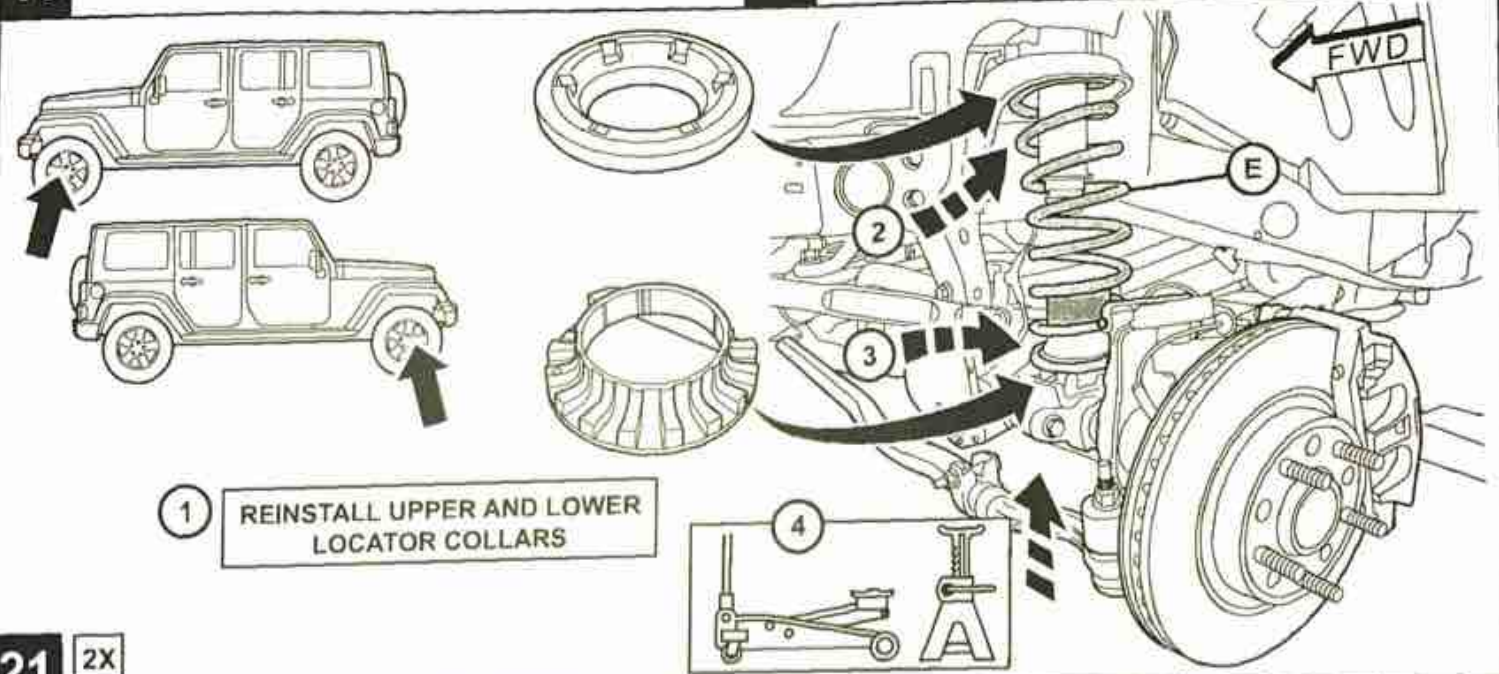
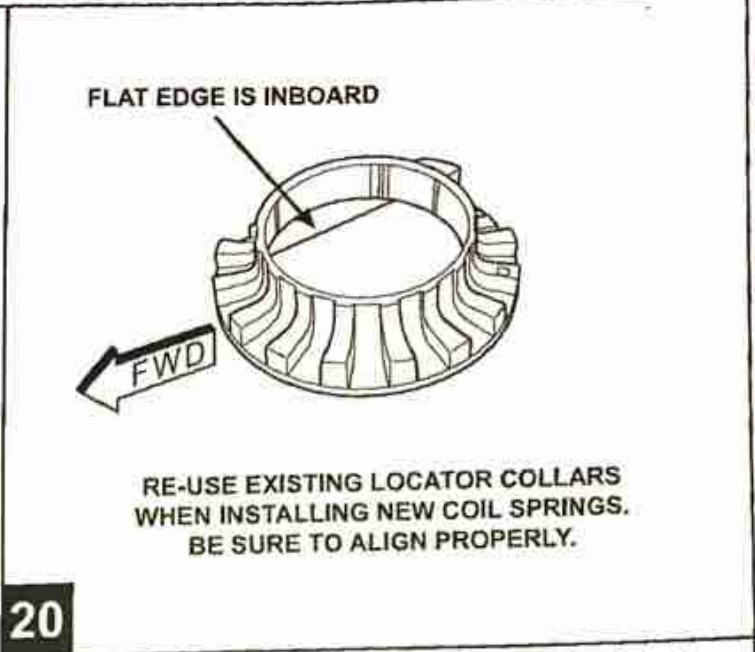
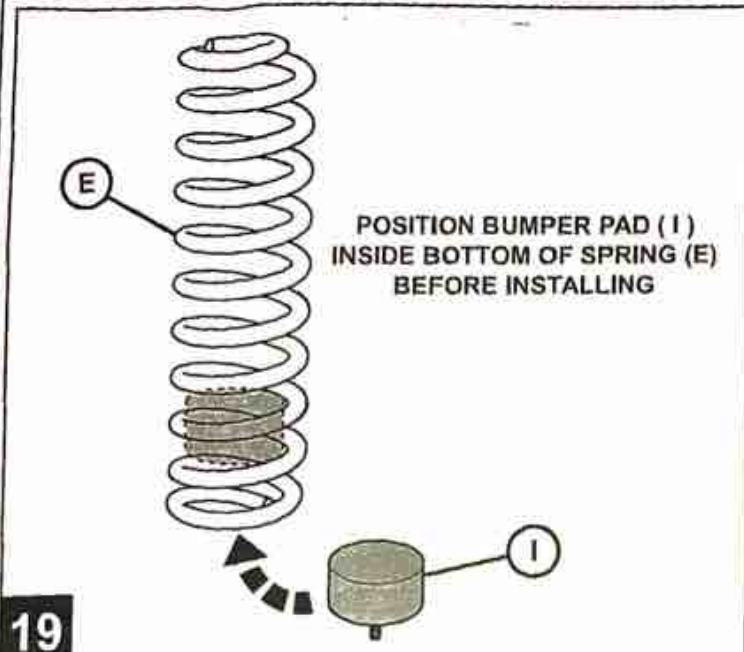

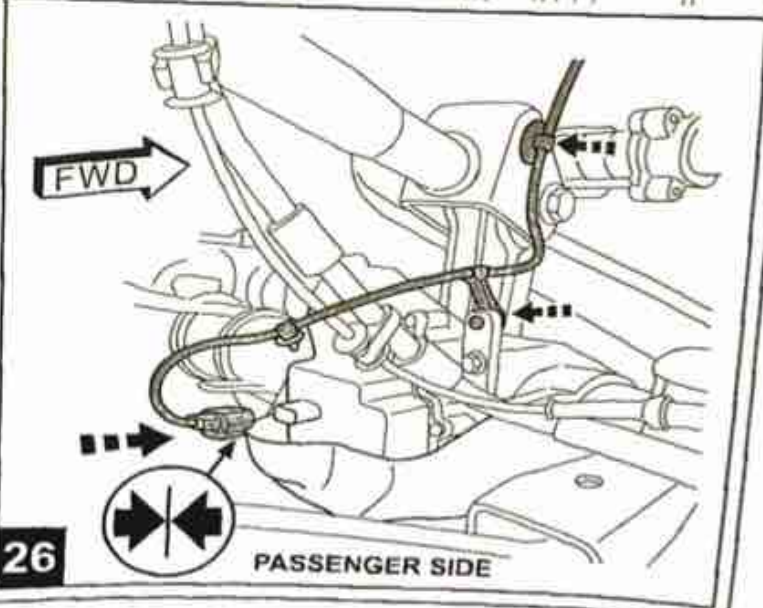
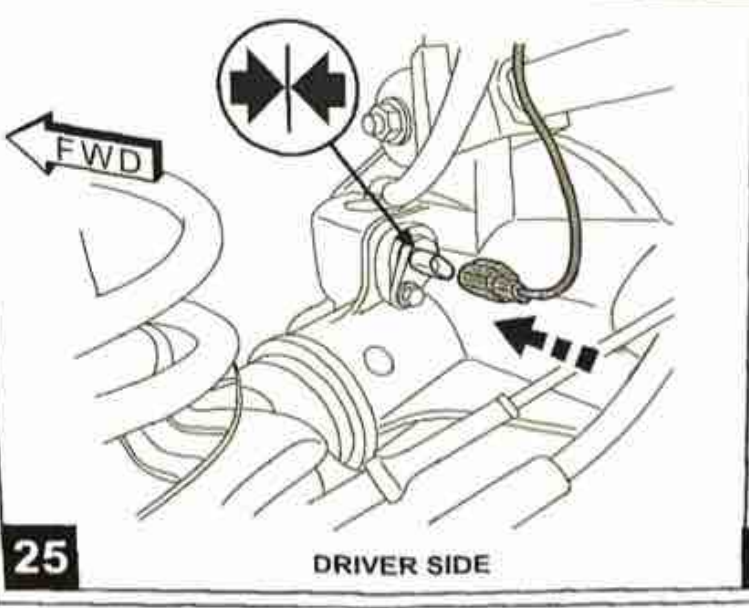
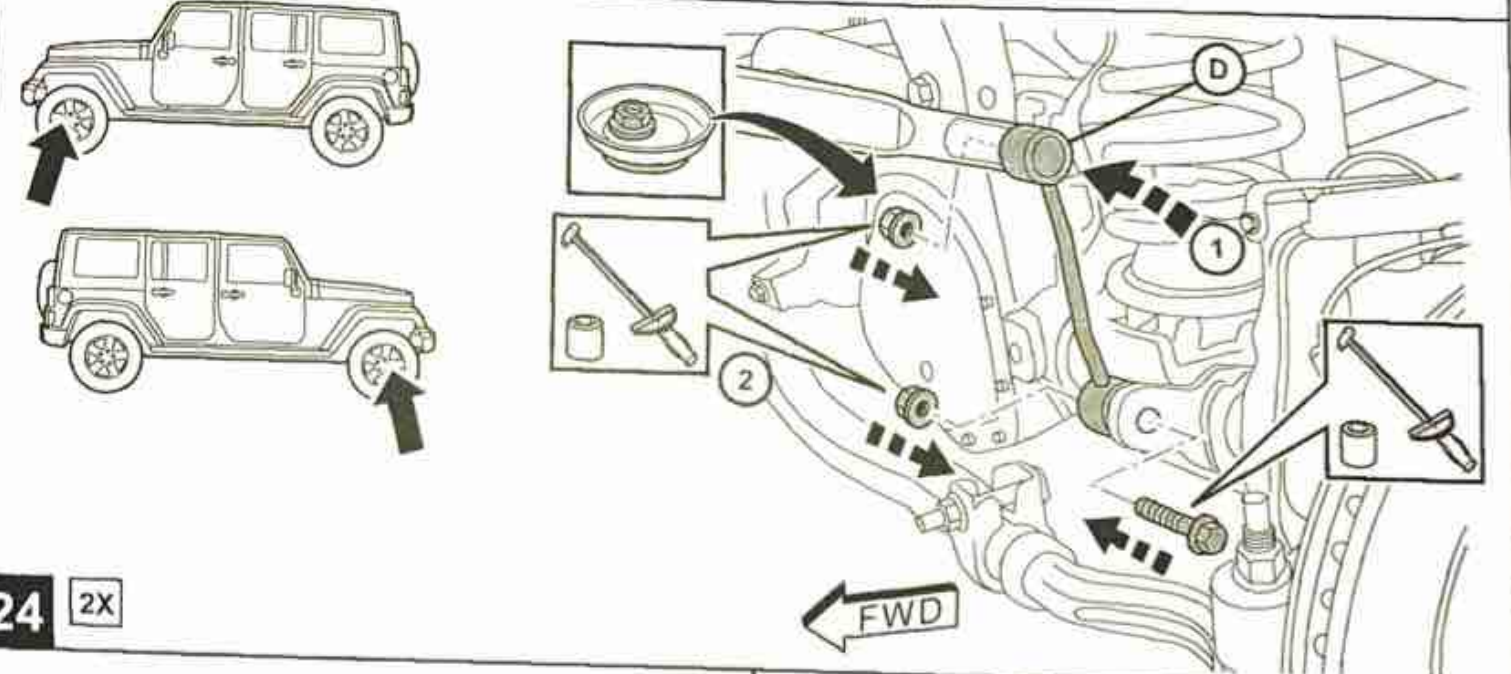
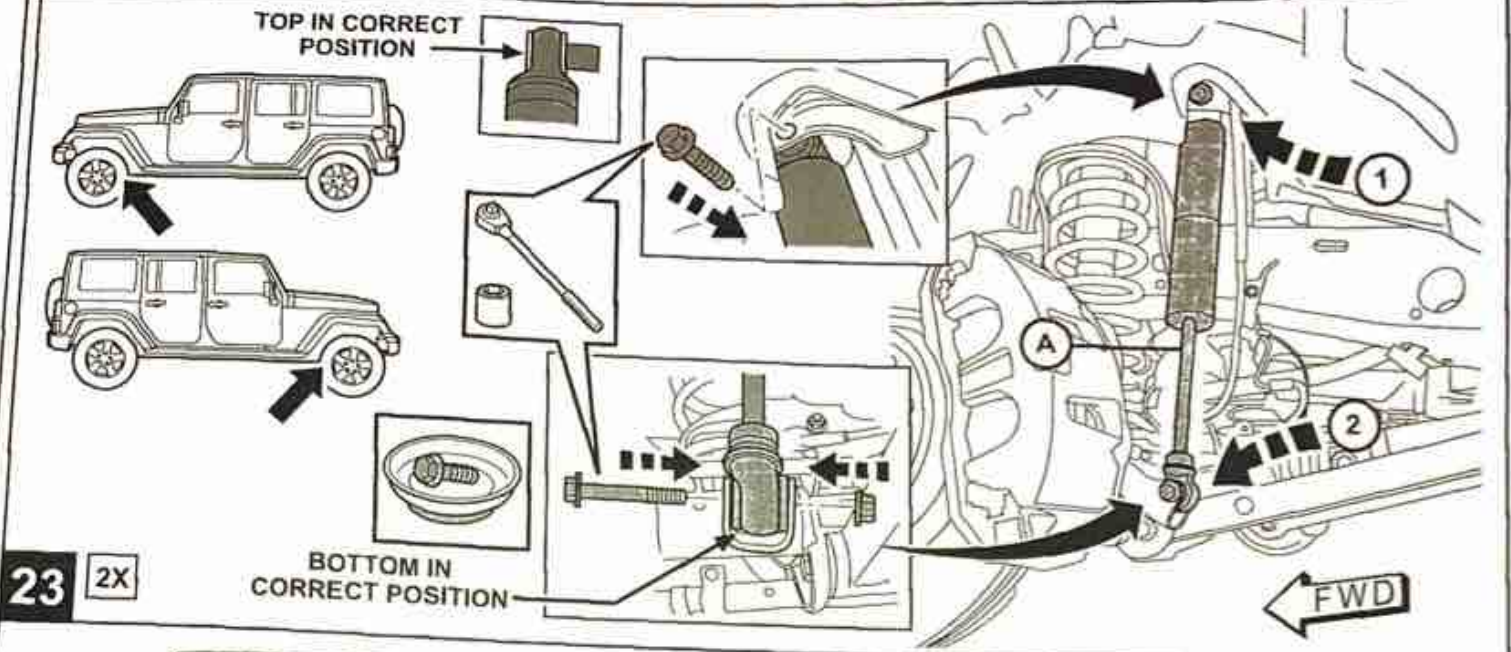

REAR DISASSEMBLY

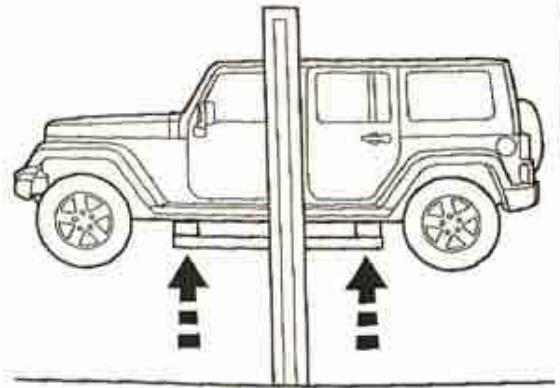
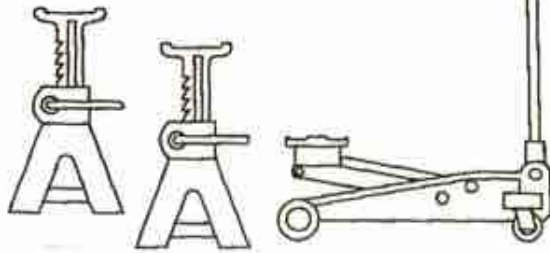
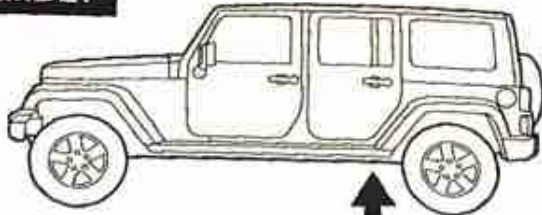

27

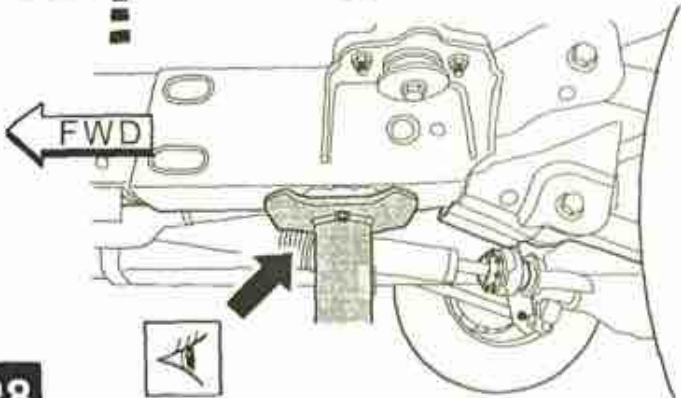
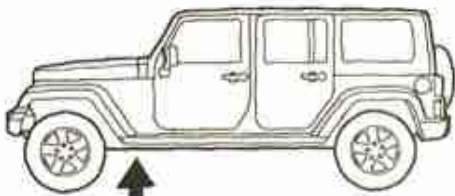

28

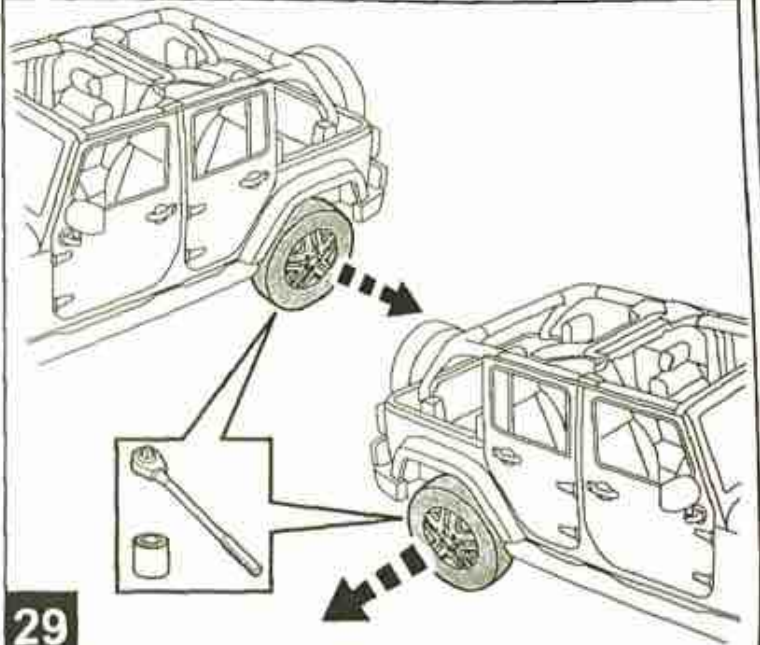

29

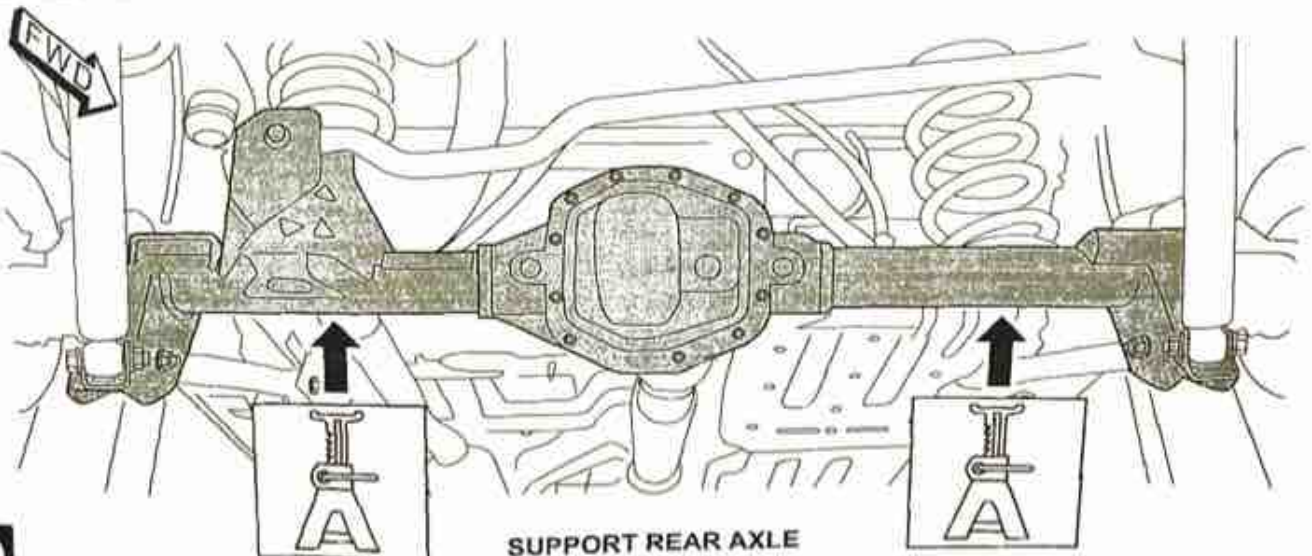

30

SUPPORT REAR AXLE

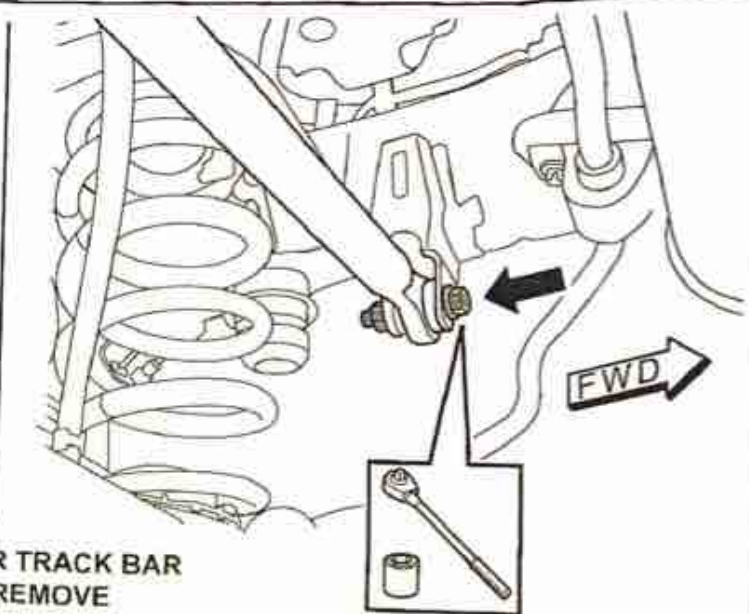
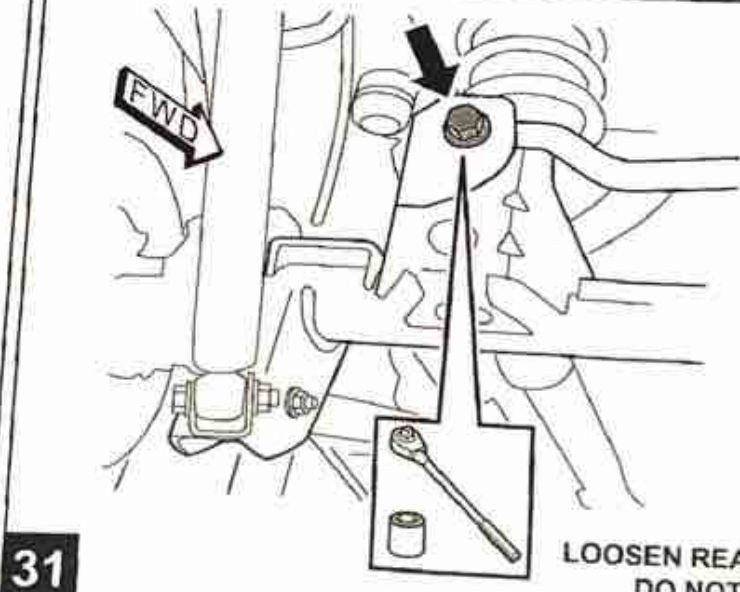

31

LOOSEN REAR TRACK BAR
DO NOT REMOVE

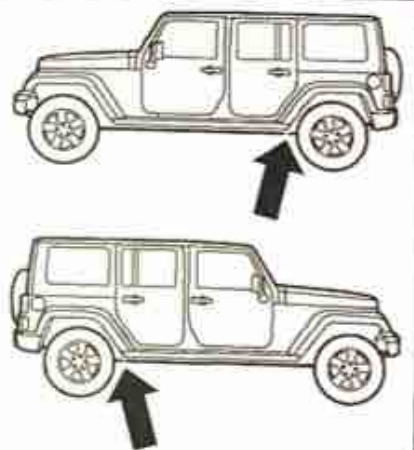
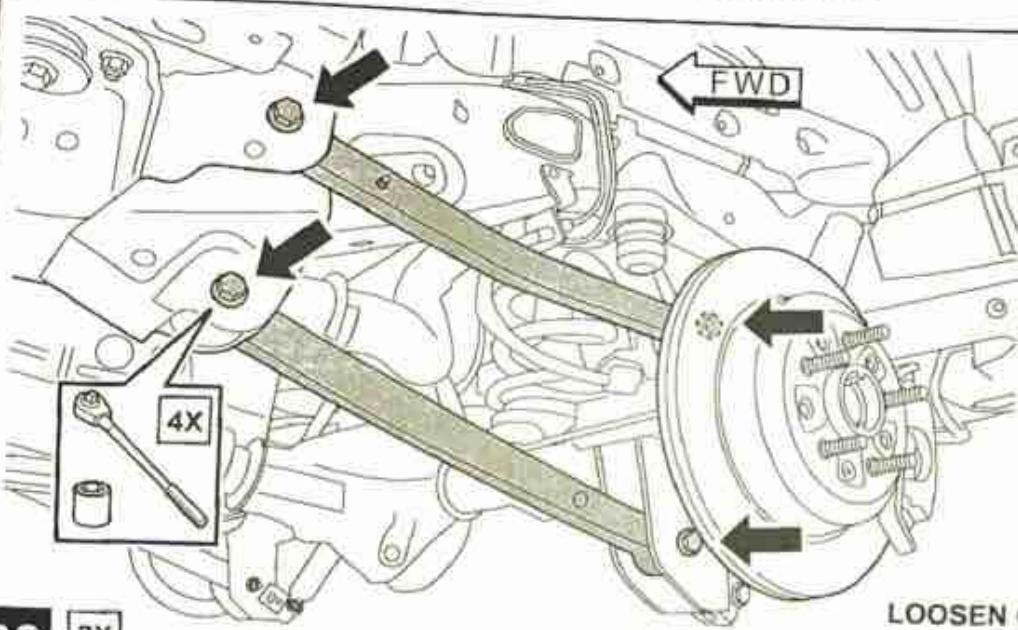

32

2X

LOOSEN CONTROL ARM BOLTS
DO NOT REMOVE

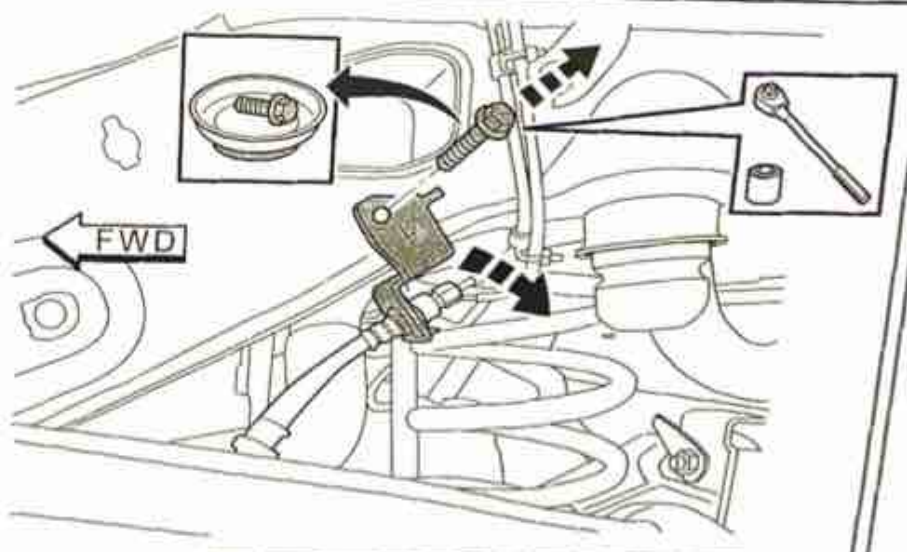
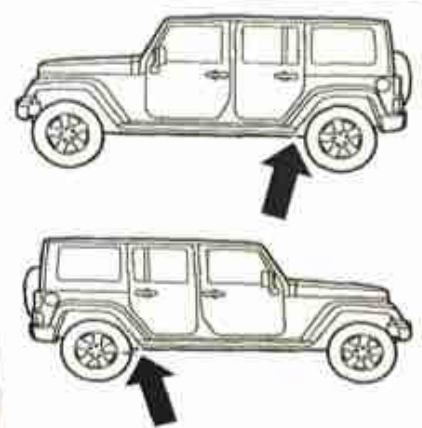

33

2X

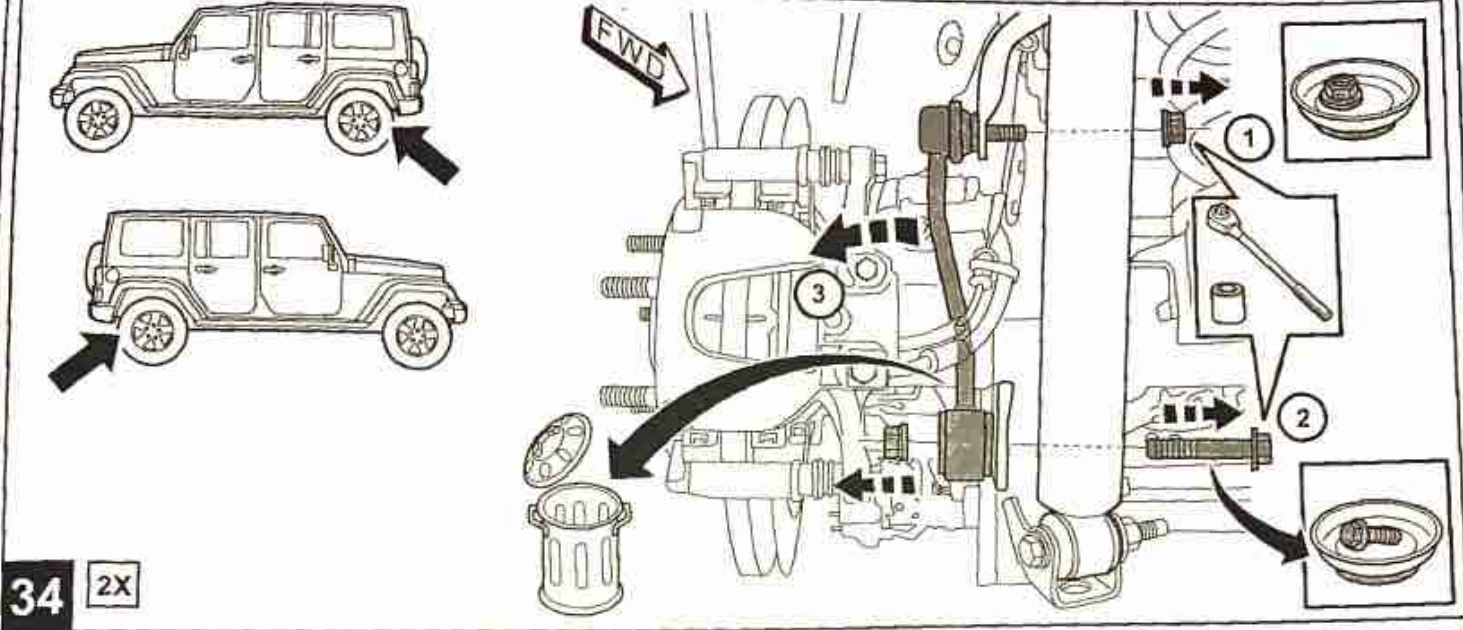

34 2X

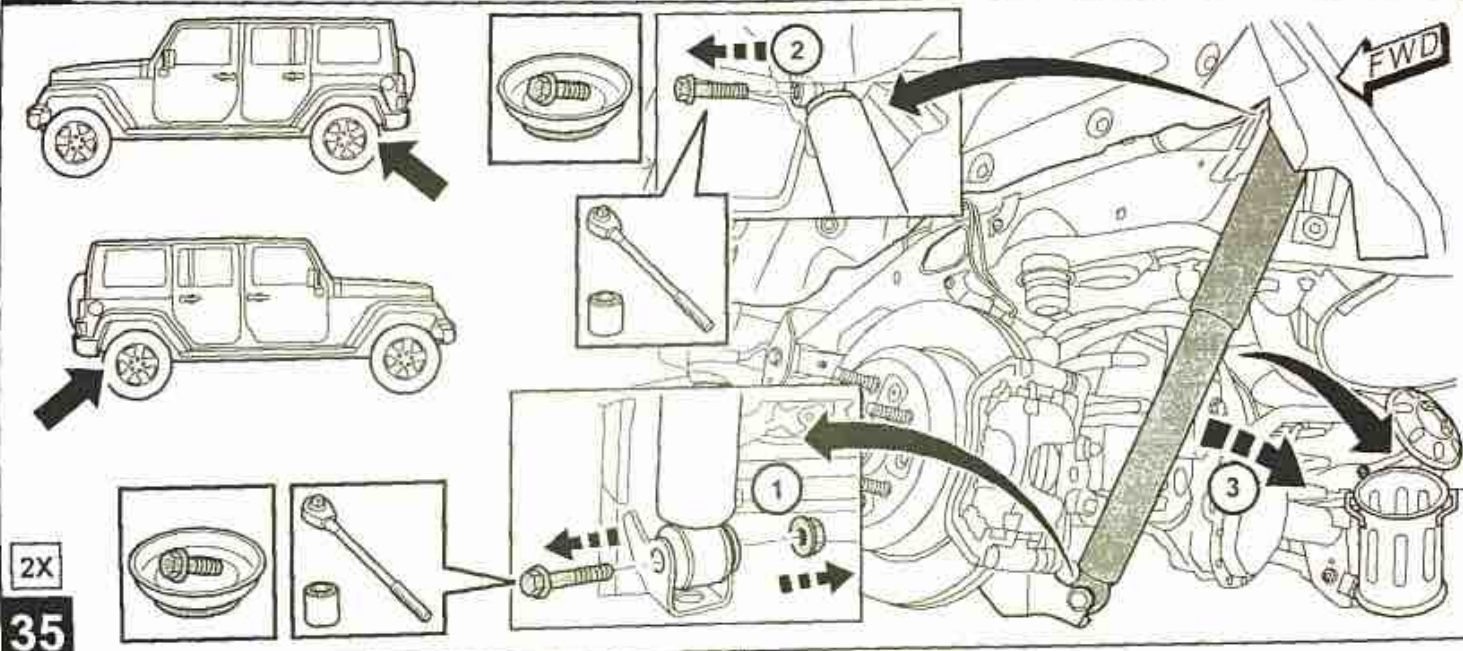

2X 35

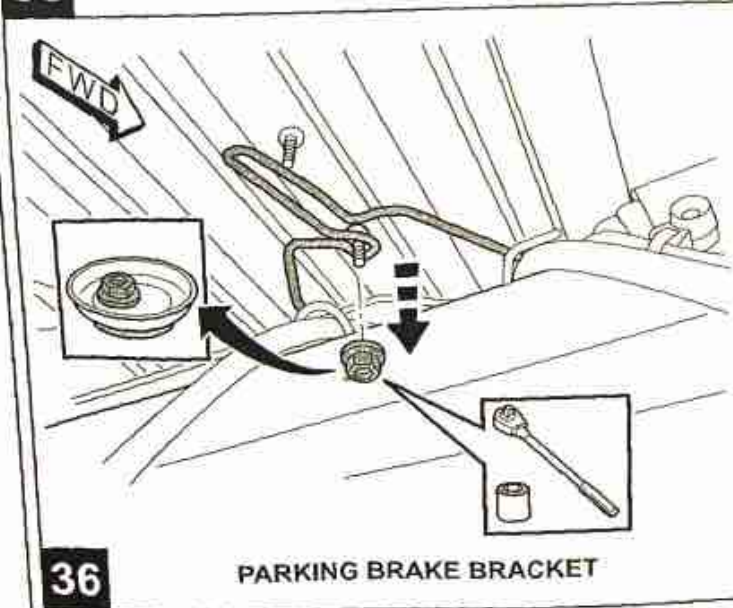

36 PARKING BRAKE BRACKET

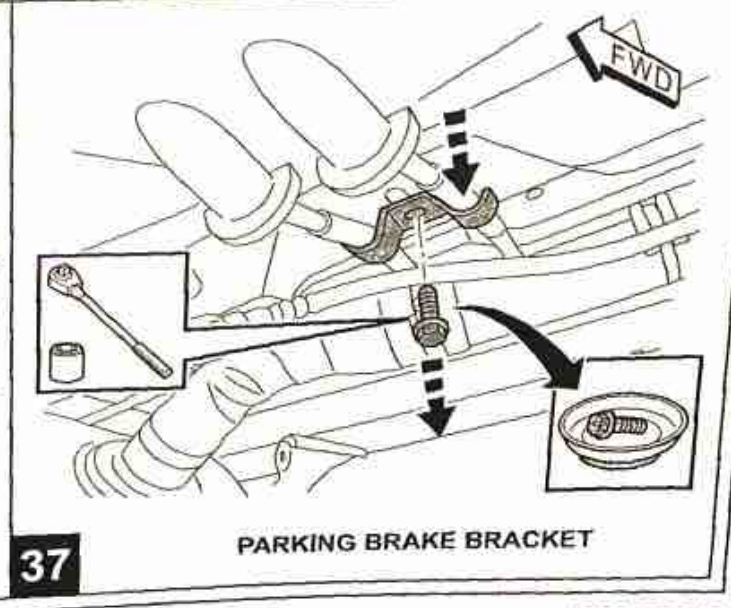

37 PARKING BRAKE BRACKET

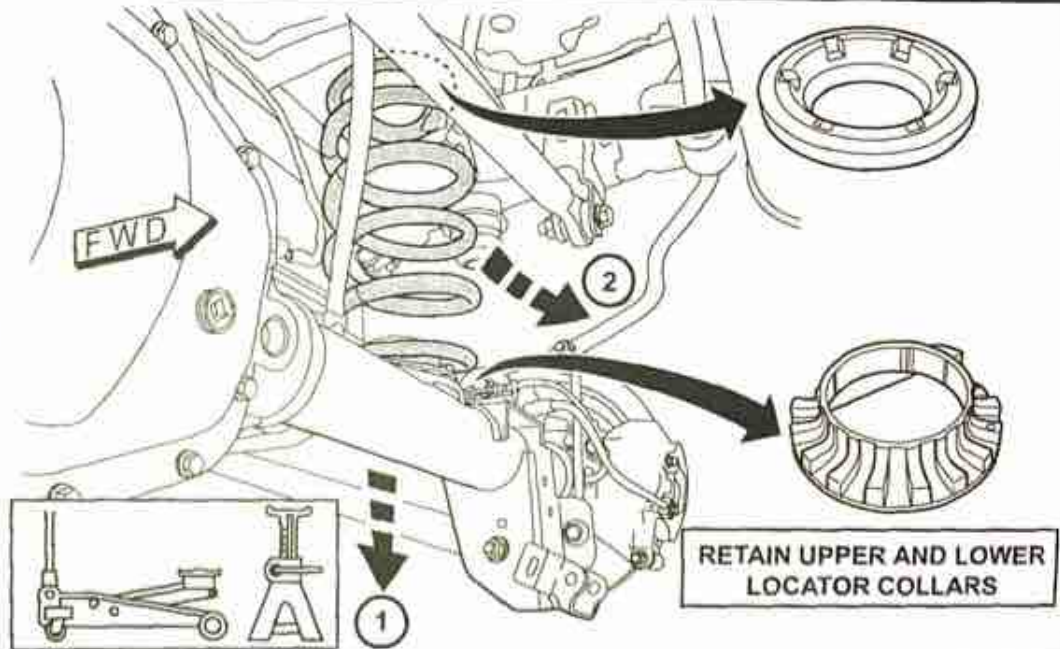
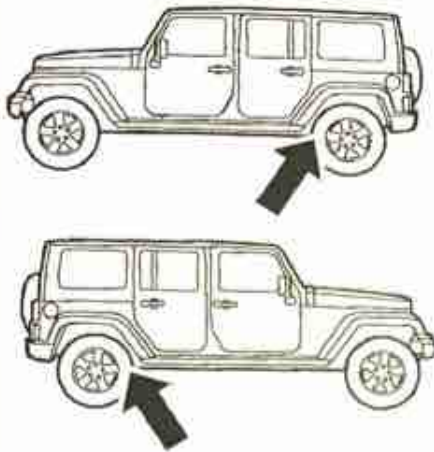
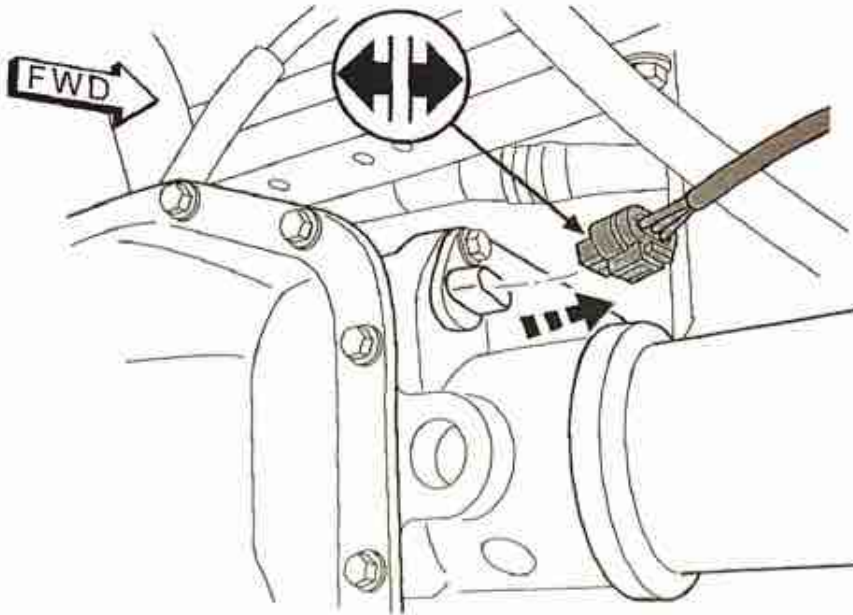

REAR ASSEMBLY

NOTE:

INSTALL NEW KIT COMPONENTS AS SHOWN IN THE FOLLOWING STEPS, BUT DO NOT FULLY TIGHTEN FASTENERS UNTIL INSTRUCTED TO DO SO.

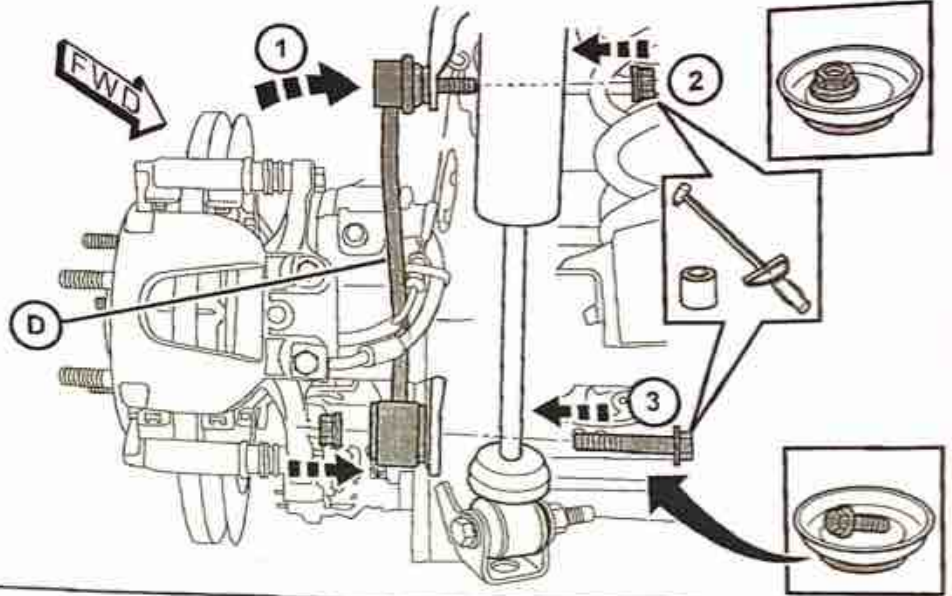
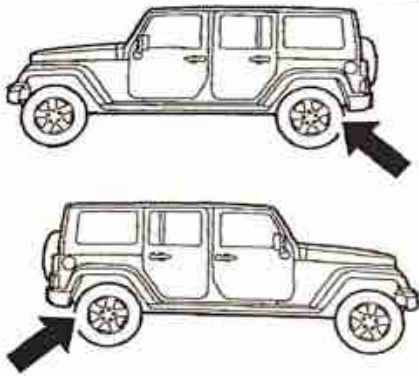

44 2X

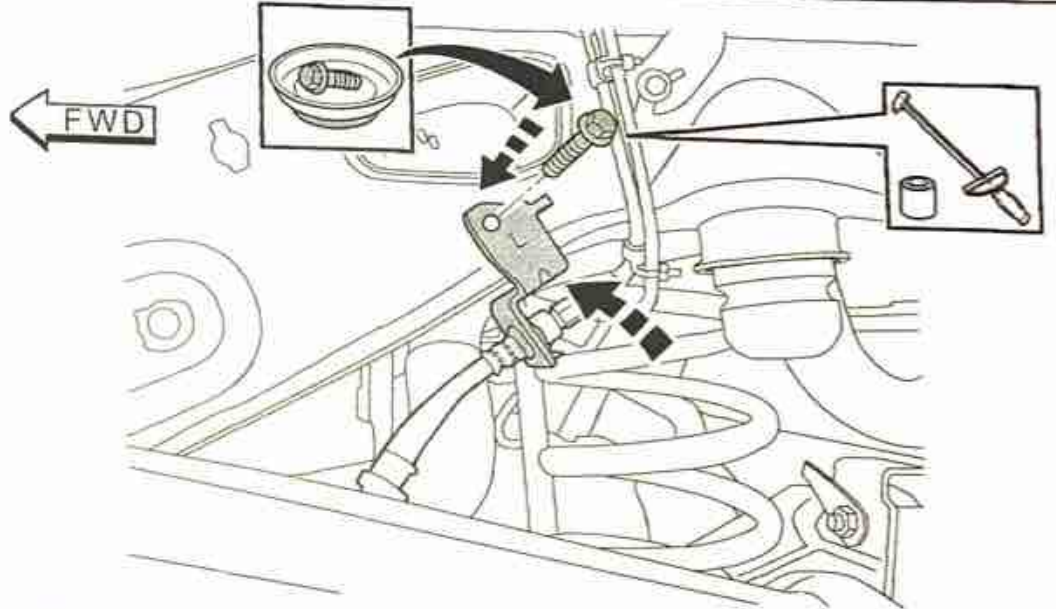
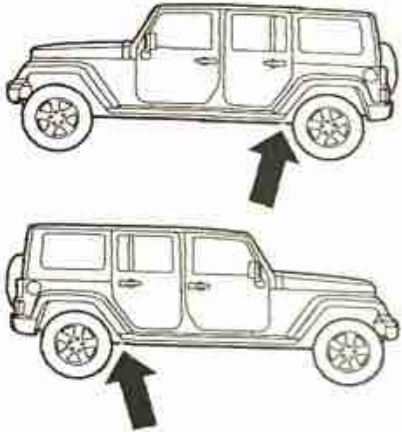

45 2X

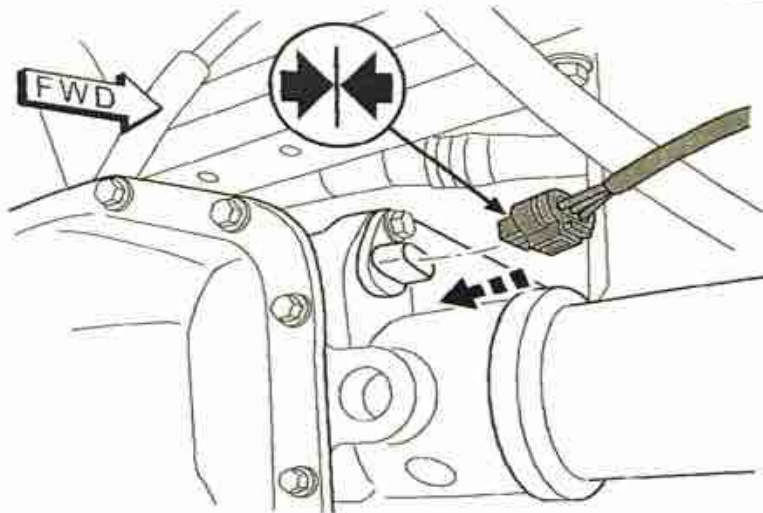

46

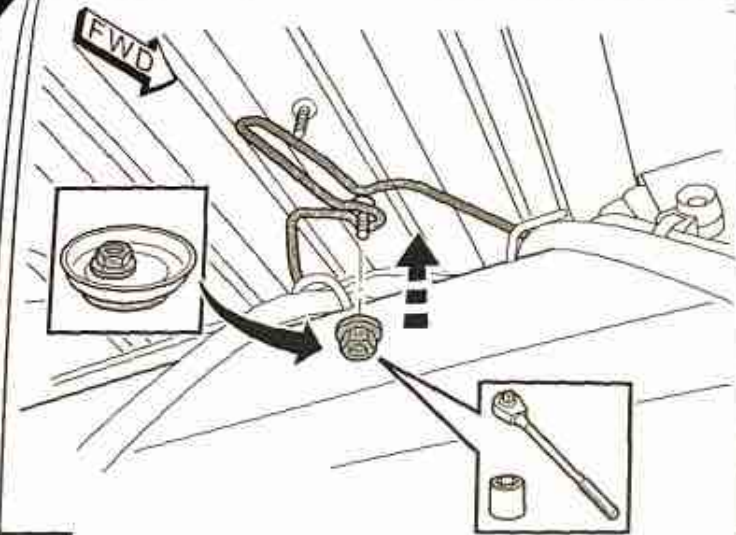

47

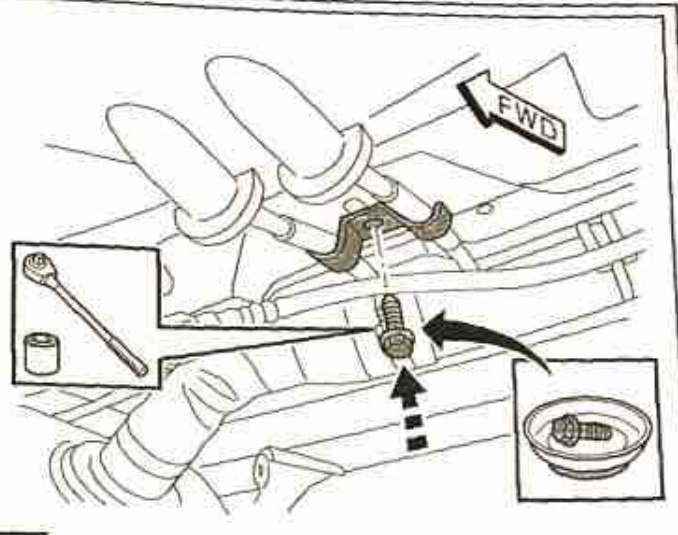

48

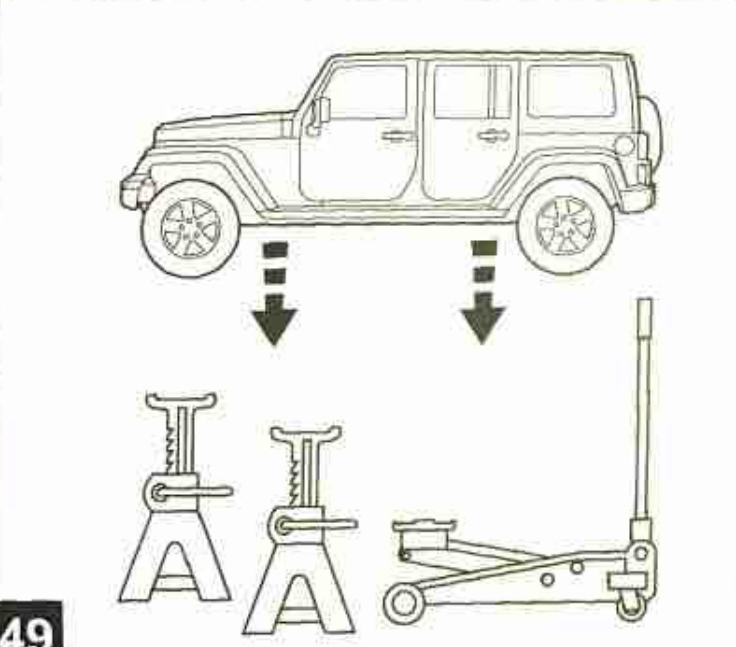

49

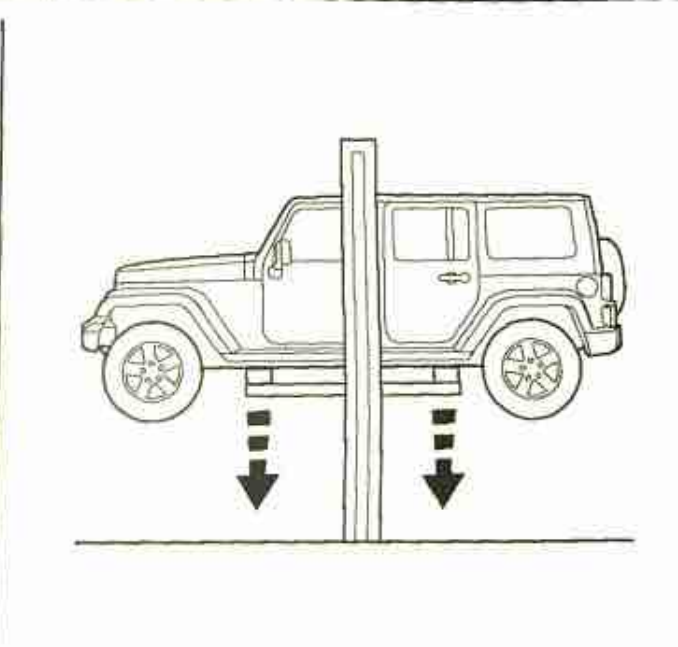

REFER TO SPECIFICATIONS ON THE FOLLOWING PAGES
TO COMPLETE THESE INSTALLATION STEPS:

- 1) TORQUE VALUES
- 2) WHEEL ALIGNMENT
- 3) HEADLAMP ADJUSTMENT

50

TORQUE SPECIFICATIONS

Joint	P/N	Size	Wrench Size (in)	Torque ft-lb
FRT UCA to Axle	Bolt - 06512084AA	M12x1.5x88.5	18	80
	Nut - 06104718AA	M12x1.5	18	
FRT UCA to Frame	Bolt - 06512084AA	M12x1.5x88.5	18	80
	Flag Nut - 06511834AA	M12x1.5	21	
FRT LCA to Axle	Bolt - 06512085AA	M16x1.5x104	21	190
	Nut - 06104720AA	M16x1.5	24	
FRT LCA to Frame	Bolt - 06512085AA	M16x1.5x104	21	190
	Nut - 06104720AA	M16x1.5	24	
FRT Brake Hose to LCA				15
	Nut - 06512384AA	M8x1.75	15	
FRT Track Bar to Axle	Bolt - 06512061AA	M14x1.5x74.15	21	110
	Flag Nut - 06512106AA	M14x1.5	21	
FRT Track Bar to Frame	Bolt - 06512061AA	M14x1.5x74.15	21	110
	Nut - 06104719AA	M14x1.5	21	
FRT Stabar Link to Axle	Bolt - 06512065AA	M12x1.5x75	18	60
	Nut - 06104718AA	M12x1.5	18	
	Flag Nut - 06508590AA	M12x1.5	18	
FRT Stabar to Frame	Bolt - 06508224AA	M10x1.5x25	15	45
FRT Stabar Link to Stabar				60
	Nut - 06502697		18	
FRT UCA Heat Shield to Frame	Bolt - 06509319AA	M6x1.0x21.8	10	40 in-lbs
FRT Lower Shock to Axle	Bolt - 06512084AA	M12x1.5x88.5	18	75
	Nut - 06510676AA	M12x1.5	18	
FRT Upper Shock to Frame	Bolt - 06512467AA	M12x1.5x120	18	80
RR UCA to Axle	Bolt - 06512063AA	M14x1.5x104.15	21	95
	Flag Nut - 06508598AA	M14x1.5	21	
RR UCA to Frame	Bolt - 06512063AA	M14x1.5x104.15	21	120
	Flag Nut - 06508786AA	M14x1.5	21	
RR LCA to Axle	Bolt - 06512063AA	M14x1.5x104.15	21	90
	Nut - 06104719AA	M14x1.5	21	
RR LCA to Frame	Bolt - 06512063AA	M14x1.5x104.15	21	90
	Nut - 06104719AA	M14x1.5	21	
RR Track Bar to Axle	Bolt - 06512061AA	M14x1.5x74.15	21	90
	Flag Nut - 06508593AA	M14x1.5	21	
RR Track Bar to Frame	Bolt - 06512061AA	M14x1.5x74.15	21	90
	Nut - 06104719AA	M14x1.5	21	
RR Stabar Link to Axle	Bolt - 06512065AA	M12x1.5x75	18	60
	Nut - 06104718AA	M12x1.5	18	
RR Stabar to Frame	Bolt - 06508224AA	M10x1.5x25	15	50
RR Lower Shock to Axle	Bolt - 06512084AA	M12x1.5x88.5	18	75
	Nut - 06510676AA	M12x1.5	18	
RR Upper Shock to Frame	Bolt - 06105106AA	M12x1.5x110	18	80
Front Bump Stop		M8x1.25x20	18	80
	Nut	M8x1.25		
Rear Bump Stop	Bolt - 05143356AC	M8x1.25x21	18	80
	Nut - 06101695	M8x1.25		

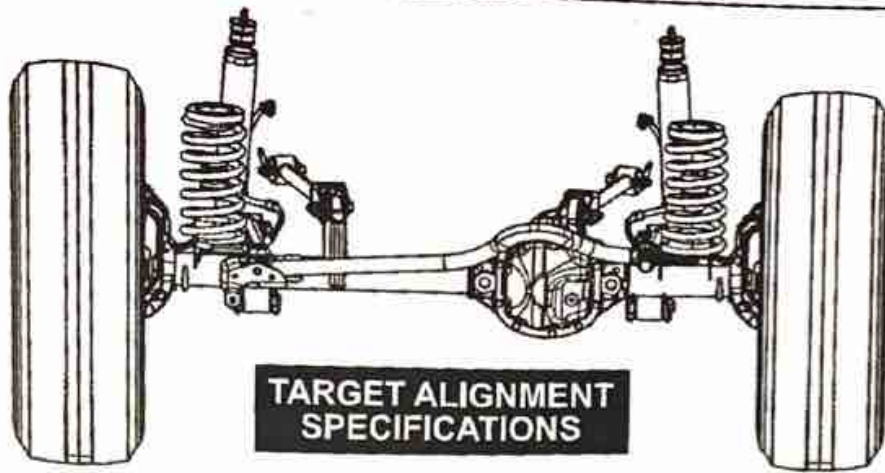

TARGET ALIGNMENT SPECIFICATIONS

LEFT FRONT

CAMBER
 $- 0.25^\circ \pm 0.37^\circ$
 (FIXED, CAN NOT BE ADJUSTED)

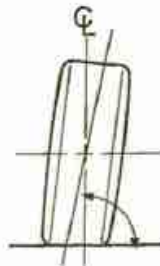

RIGHT FRONT

CAMBER
 $- 0.25^\circ \pm 0.37^\circ$
 (FIXED, CAN NOT BE ADJUSTED)

CASTER
 $4.80^\circ \pm 1.00^\circ$

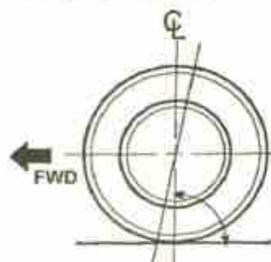

CASTER
 $4.80^\circ \pm 1.00^\circ$

TOE-IN
 $0.0^\circ - 0.12^\circ$

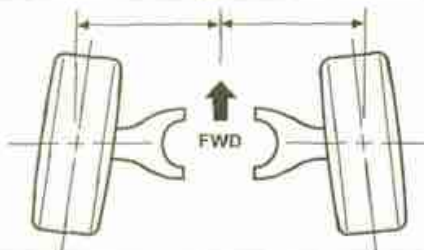

TOE-IN
 $0.0^\circ - 0.12^\circ$

THRUST ANGLE
 $0.0^\circ - 0.25^\circ$

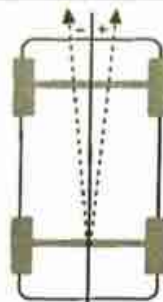

TOTAL TOE-IN
 $0.0^\circ - 0.20^\circ$

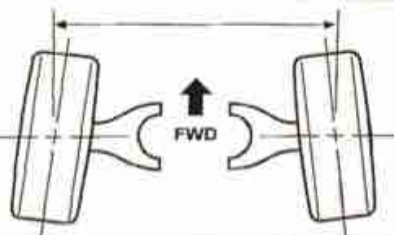

HEADLAMP ALIGNMENT

1. Verify proper tire inflation pressures.
2. Verify that there is no extra weight load in the vehicle except for the driver.
3. The fuel tank should be FULL.
4. Prepare an alignment wall according to diagram below:

