

Wire Connection Summary

<u>OEM Harness</u>	<u>Cool Tech Color</u>	<u>Function</u>
Yellow	Yellow	Left Stop/Turn
Green	Green	Right Stop/Turn
White/Gray Stripe	White	Left Park Lamp
White/Orange Stripe	Orange	Right Park Lamp

Sheathed Cable:

Yellow: Left Stop/Turn
Green: Right Stop/Turn
Red: Parking Lights
Brown: Ground

IMPORTANT USE Information

The switch has been labeled for your convenience. When Towing the Jeep, the switch should be in the "TOW" Position. When you are not towing, the Jeep should be in the "JEEP" position. **It is EXTREMELY IMPORTANT that you remember to place switch back to "JEEP" position before you drive.** If you start to drive the Jeep and notice that the turn signals blink rapidly, and/or you get a message that a rear bulb is out, it is an indication that the switch is in the wrong position!!

Please try to be extra diligent to return the switch to "JEEP" mode before driving.

Warranty

Should your JL Tow Harness fail due to a defect in materials or workmanship, it will be repaired or replaced at the discretion of the manufacturer. This service is provided to the original purchaser and requires dated proof of purchase. The warranty period is for 1 year from date of purchase. Damages caused by abuse, misuse, or negligence are avoidable circumstances and not covered by this warranty.

Warranty claims can be addressed to:

Cool Tech, LLC
25071 Wintergreen Ct.
Newhall, CA 91381
sales@cooltechllc.com
www.cooltechllc.com



TOWING HARNESS KIT

2018+ Jeep Wrangler JL

+ *Installation*

+ *Warranty Information*

Revision 3.0
July 2018

Installation

Thank you for purchasing Cool Tech's Tow Harness Kit for the 2018+ Jeep Wrangler JL. Cool Tech LLC has more than a decade of experience designing and building tow wiring solutions for Jeep Wranglers and we've applied that know-how to make what we believe is the best solution available for the Wrangler JL. Please read through the instructions before starting and don't forget to look at the Addendum Sheet as it will contain all of our latest updates.

Step 1: Remove Front Passenger Side Kick-Panel & Sill Trim

Please start by removing the plastic cover around the nylon strap that holds the passenger front door. To remove, pull this cover toward the back of the car. Now lift the red safety tab, press the black tab, and then rotate the white lever to disconnect the wiring harness from the door. Finally, lift and release the nylon strap off of the black hook. Remove the 10mm nut securing the kick panel inside the access panel cover you just removed. Remove the kick panel and integrated door sill piece. ALL of the plastic snaps (even the ones by the sill), are released by pulling the panel toward the center of the car – not upward. Set the kick panel aside.

Step 2: Remove the Gray Plastic Sill Wire Guard

Remove the 10mm nuts securing the gray protective sill cover and then use a small flat-blade screwdriver to release the tabs while lifting up on the guard. You will need to loosen (but not remove) the bottom of the B-Pillar plastic panel so you can access the last 10mm nut securing the gray piece. (Pull the B-Pillar toward the center of the car to release, NOT upward.) Set the guard aside. Please see the addendum for more information about removing this gray wire guard.

All of the connections that you will make will be in this sill area. You may elect to remove some of the tape to make the wires more easily accessible. The kit includes some zip ties so that when you are all done with the connections you can zip tie the harness together in lieu of the tape.

Step 3: Route the Harness Wires

Familiarize yourself with where the switch will mount - see **Figure 1**, but let's route the wires before mounting the switch under the seat bracket. Route the wires back and under the carpet and then loop them around to come forward. Bring the bundle of wires under the "T" of the OEM bundle and lay them out along the existing wires in the door sill area. See **Figure 2**.

Step 9: Reassemble the Trim Pieces

Re-install the gray plastic wire tray protector and secure with the hardware you removed. Next, carefully re-install the kick panel plastic trim and carefully snap it back into place. Finally, re-connect the door wire harness (rotate the white lever to draw the connection together) and then press down on the red safety tab. Place the nylon strap hoop back onto the black hook.

If you removed fuses F107 and F109 in Step 5, put them back in place now.

Step 10: 6-pin Socket Mounting & Wiring

Determine the best location for mounting the 6-pin socket at the front of the Jeep. Consider which side of your tow vehicle the trailer connector is on. When you have found a suitable location, mount the mounting bracket and then mount the socket to the bracket with the hardware provided.

If you plan to use a system to maintain the Jeep's battery while towing, then refer to **Figure 7** and add an additional grounding connection for the additional current. A Blue butt connector, short segment of wire and a length of wire with an eye connector is included with our Deluxe Kit for this purpose. Find a suitable grounding location (typically a bumper bolt) and then cut and attach the additional grounding point.

A ~2" length of heat shrink has been included in the kit. Route all of the wires that will go into the 6-pin socket through this heat shrink and then make your connections to the socket. (See **Figure 6** for standard wiring of this socket.)

If you are adding the RVI Towed Battery Charger included in our Deluxe Kit, route the (+) MH wire through the heat shrink sleeve and connect it to the center post of the 6-pin socket.

After the 6-pin socket has been wired and tested, slide the supplied heat shrink tubing partially onto the socket and then heat-shrink it into place to protect the wires.



- 1 Lay Cool Tech Harness on existing OEM Harness
- 2 Cut Green Wire so that it can be inserted into butt connector

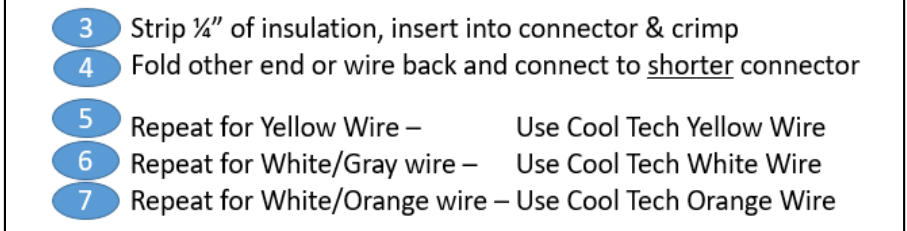
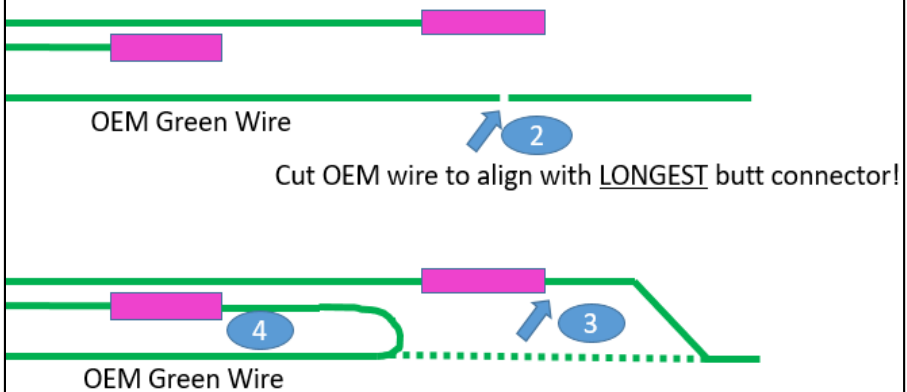

- 3 Strip ¼" of insulation, insert into connector & crimp
- 4 Fold other end of wire back and connect to shorter connector
- 5 Repeat for Yellow Wire – Use Cool Tech Yellow Wire
- 6 Repeat for White/Gray wire – Use Cool Tech White Wire
- 7 Repeat for White/Orange wire – Use Cool Tech Orange Wire

Figure 5 (Step 7)

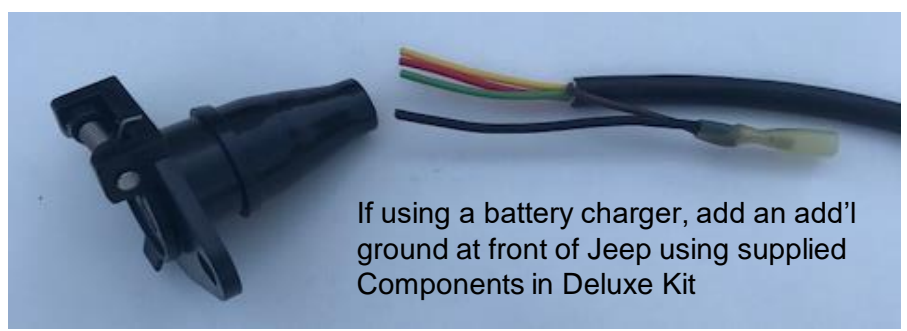

Figure 7 (Step 10)



Figure 1 (Step 3)

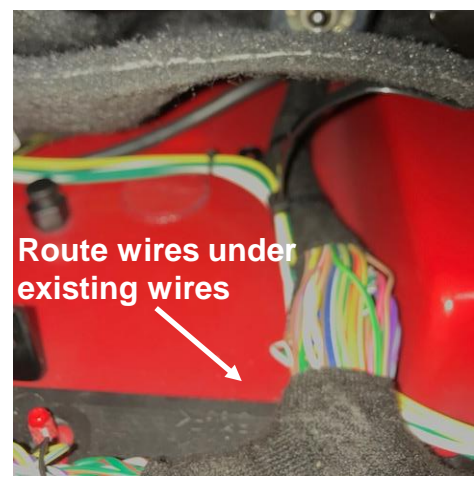

Figure 2 (Step 4)



Figure 3 (Step 4)

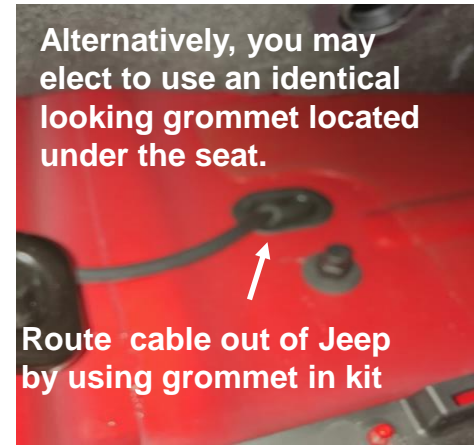

Figure 4 (Step 4)

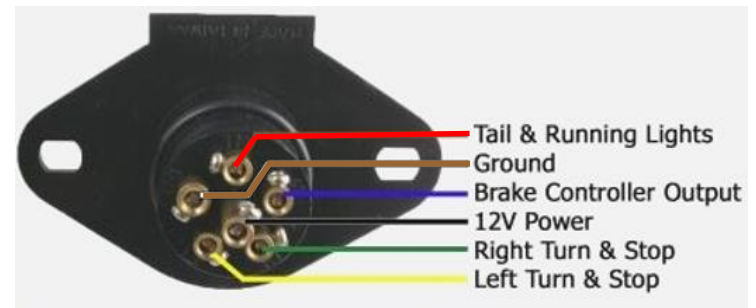

Figure 6 (Step 10)

Step 3: Route the Harness Wires (con't)

Position the wires so that the longest wires with the butt connectors are located as shown in **Figure 3**. Take up any slack by enlarging the loop under the seat. Try to keep the wire bundle away from the plastic carpet posts.

Refer to **Figure 4** and route the black sheathed cable as shown. Remove the rubber floor grommet at the floor pan at the front edge of the seat and then feed the free end of the harness through the grommet included with the kit. Alternatively, there is an identical rubber grommet underneath the seat. You can use this identical grommet to route the black sheathed cable out of the Jeep. Adjust the sheathed cable so that it is routed as shown and there is no tension and then place the grommet in the hole. Under the Jeep, carefully route the harness cable toward the front bumper – avoiding the hot exhaust components and the front suspension. Use the zip-ties in the kit to secure the cable strategically along a path to the front bumper area. (We'll come back to this harness in a later step.)

Step 4: Mount the Switch & Bracket

Using a T50 Torx socket, remove the front right seat bolt from the passenger seat bracket. With the bolt removed, slide the switch bracket under the seat bracket (but on top of the carpet) and align the hole in the bracket with the bolt hole. Install and tighten the T50 Torx bolt.

Step 5: Route & Connect the Ground Wire

Route the Cool Tech Black wire forward to the kick-panel area. Connect the ring of the Black wire to one of the (preferably used) grounding posts and secure with the 10mm nut already in place.

Step 6: Identify & Confirm the OEM Wires

You will need to locate (4) specific wires in the bundle of wires along the passenger door sill. Namely;

Green:	Right Stop/Turn
Yellow:	Left Stop/Turn
White/Orange Stripe:	Right Parking Lamp
White/Gray Stripe:	Left Parking Lamp

If your Jeep is equipped with the Factory 7-pin Trailer Harness Package, refer to the Addendum Sheet and temporarily remove fuses F107 and F109. This will insure that you don't accidentally sense one of these wires in the next step. (See picture on Addendum Sheet.)

You MUST use a 12v wire (sharp) probe to insure that you have identified each of these wires. For example, turn on the Left Turn Signal, and pierce the Yellow wire to confirm that it is blinking. If it is not blinking, you are not on the correct yellow wire. Repeat this for the right turn signal and probe the Green wire.

For the parking lights, switch them on and then probe the White/Gray stripe wire for a 12v signal. Verify that you DO NOT get this signal with the lights off. Repeat the process to find the White/Orange Stripe wire.

Hint(s):

All of these OEM wires are the exact same size (diameter). The Green wire you want is the brighter of the two green wires present.

Please refer to the Addendum regarding Step 6 before proceeding.

Step 7: Connect the Cool Tech Harness

Now you have the 4 wires that we will cut identified from Step 5. With the Cool Tech wire bundle laying neatly on top of the OEM harness bundle, locate the LONGEST Green wire (with a butt connector already attached), and cut the OEM Green wire so that you can attach the LONGEST Green wire to it at the location you just cut. **As soon as you have cut the Green wire, PLEASE double check that the Right turn signal no longer works. It better not! Do this double-check after you cut each wire to avoid any downstream aggravation!** Refer to **Figure 5**. After you have crimped this connection, fold back the OEM Green wire and crimp it into the SHORTER (and thinner) Green wire in our kit.

Note: It is VERY important that you attach the LONGER of the Cool Tech Harness wires to the location you cut (toward the front of the Jeep) and then fold back the OEM wire to the SHORTER, thinner, Cool Tech wires. In other words, the OEM wires that are going toward the BACK of the Jeep MUST be connected to the thinner wires that are shorter and also have pre-installed butt connectors

Now, repeat this process for the remaining 3 wires as described in **Figure 5**.

Step 8: Heat Shrink the Connections

It is recommended, but not mandatory that you heat shrink these butt connectors. Please use a heat gun (NOT a flame) and be very careful to apply the heat from a distance so that you do not burn the insulation. Take your time. When done, zip tie the wire bundle neatly together as shown.

Tow Harness Installation – Addendum Side 1

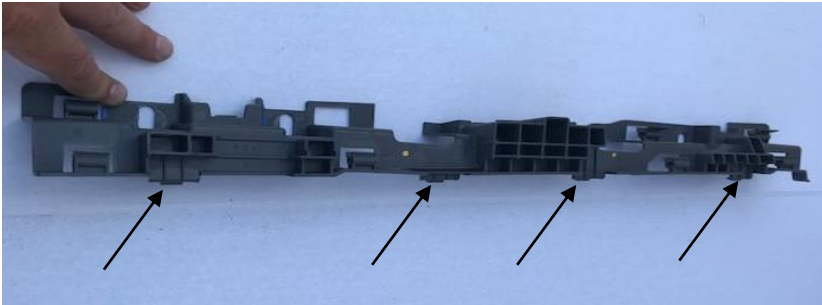

While lifting the panel, use a small screwdriver to release these tabs. Work from front to back, releasing one tab at a time.

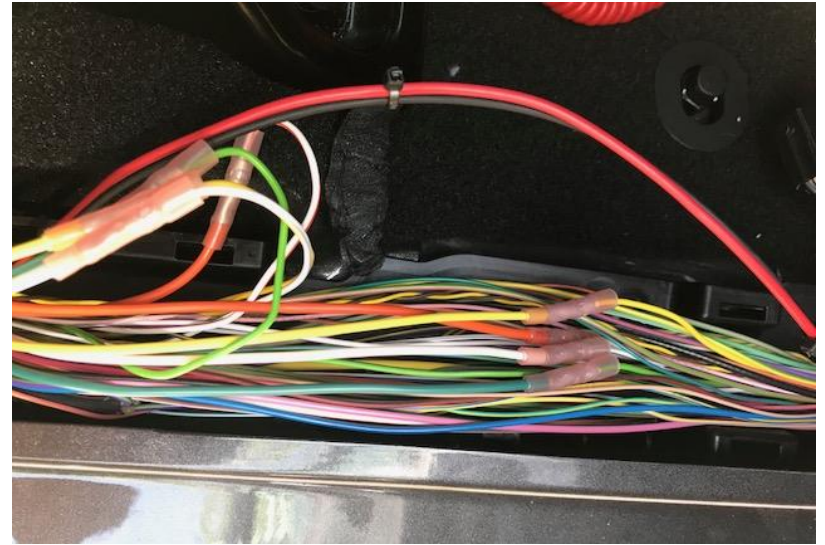

All the connections are made. The OEM Wires are cut and connected at the longest butt connector and then the other end of the OEM wire if folded back to the shorter butt connector.



Here the connectors have all been heat-shrunk and the supplied zip-ties used to tidy everything up. Now it's time to re-install the gray wire tray protector. Take your time and insure that you don't pinch any wires.

Note:

If you drive the Jeep with the switch in the TOW position, it will not “see” its lights and it will take 30 seconds or so before it will display a message. Similarly, when you flip the switch back to the correct “JEEP” position, it may take 30 seconds or so of blinker operation before the Jeep is happy to see it's lights again and everything will return to normal.

Tow Harness Installation – Addendum – Side 2



If your Wrangler has the OEM 7-pin Factory Trailer Wire Harness, temporarily remove Fuses F107 & F109 before probing the wires in **Step 6**. (We don't want you to mistake the trailer tow wires for the tail light wires.)

Important

In **Step 6**, you confirm the wires that will be used by probing them with a 12v test light. In Step 7, you cut and connect the wires one by one. After you cut each wire, you should confirm that it is the correct wire before proceeding. For example, after cutting the Green wire, you can quickly validate that you have cut the correct wire by observing that the right turn signal no longer operates. For your reference, the chart to the right depicts the wire colors and their function.

Green:	Right Stop/Turn
Yellow:	Left Stop/Turn
White/Orange Stripe:	Right Parking Lamp
White/Gray Stripe:	Left Parking Lamp

Compatibility w/Aux Braking Devices

In almost all other wiring solutions, when an aux braking device moves the Jeep's brake pedal, the Jeep will activate its brake lights which washes out a turn signal commanded by the tow vehicle. This will NOT happen with this kit because it is 100% isolated!!

If your aux brake device instructions wants you to tap into a wire that is 12v when the Jeep's brake pedal is pressed, you can tap into our (thicker) solid Yellow wire for this purpose.