

## C1082-VACUUM PRESSURE SENSOR CIRCUIT

For a complete wiring diagram, refer to the Wiring Information .

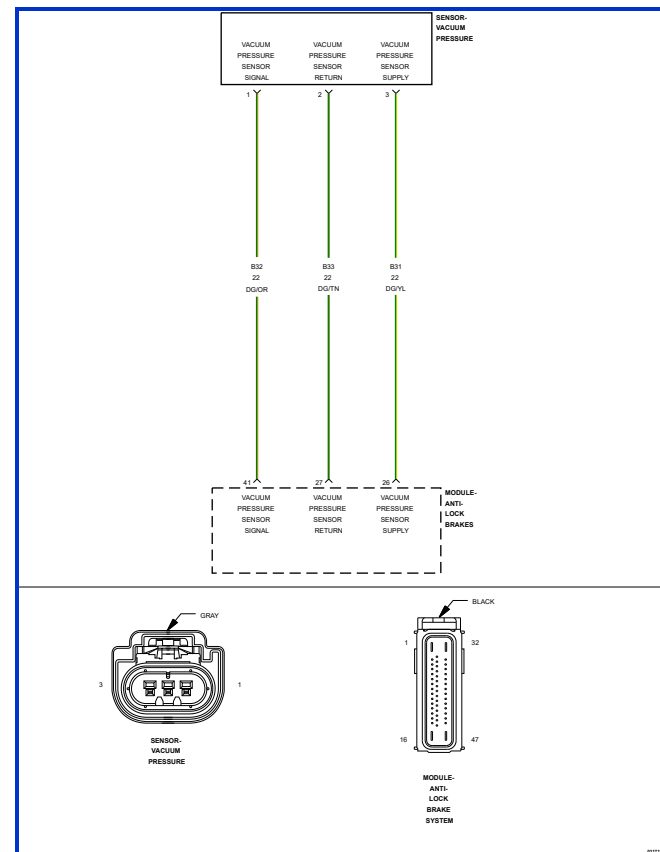

- **When Monitored:**

Continuous

- **Set Condition:**

The Vacuum Sensor Signal indicates that the voltage level is below 0.1 volt or greater than 3.5 volts for 100 msec.

### Possible Causes

(B31) VACUUM PRESSURE SENSOR SUPPLY CIRCUIT OPEN OR HIGH RESISTANCE

(B32) VACUUM PRESSURE SENSOR SIGNAL CIRCUIT SHORTED TO VOLTAGE

(B32) VACUUM PRESSURE SENSOR SIGNAL CIRCUIT SHORTED TO GROUND

(B32) VACUUM PRESSURE SENSOR SIGNAL CIRCUIT OPEN OR HIGH RESISTANCE

## Possible Causes

(B33) VACUUM PRESSURE SENSOR RETURN CIRCUIT OPEN OR HIGH RESISTANCE

VACUUM PRESSURE SENSOR

ANTI-LOCK BRAKE SYSTEM (ABS) MODULE

## Diagnostic Test

### 1. VERIFY THE DTC IS ACTIVE

---

1. Perform any Technical Service Bulletins (TSBs) that may apply.
2. Ignition on, engine not running.
3. With the scan tool, record and erase the DTCs.
4. Cycle the ignition switch from off to on.
5. With the scan tool, read the DTCs.

#### Is the DTC active at this time?

##### Yes

- Go To [2](#)

##### No

- The condition that caused the symptom is currently not present. Inspect the related wiring for a possible intermittent condition. Look for any chafed, pierced, pinched, or partially broken wires.
- Perform the ABS-INTERMITTENT CONDITION TEST. ([Refer to 28 - DTC-Based Diagnostics/MODULE, Antilock Brake \(ABS\) - Standard Procedure](#)) .

### 2. (B31) VACUUM PRESSURE SENSOR SUPPLY CIRCUIT OPEN OR HIGH RESISTANCE

---

1. Turn ignition off to the lock position.

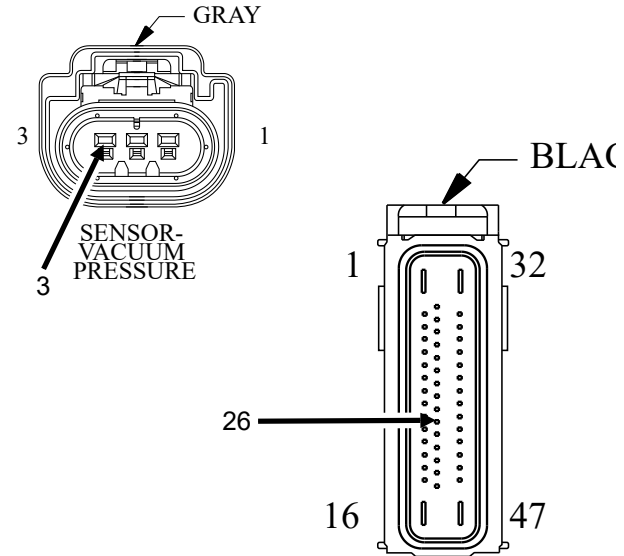
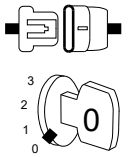
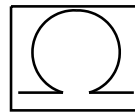

MODULE-  
ANTI-  
LOCK  
BRAKE  
SYSTEM

3172768

2. Disconnect the ABS Module harness connector.
3. Measure the resistance of the (B31) Vacuum Pressure Sensor Supply circuit between the Vacuum Pressure Sensor harness connector and the ABS Module harness connector.

**Is the resistance below 5.0 Ohms?**

**Yes**

- Go To [3](#)

**No**

- Repair the (B31) Vacuum Pressure Sensor Supply circuit for an open or high resistance.
- Perform the ABS VERIFICATION TEST. ([Refer to 28 - DTC-Based Diagnostics/MODULE, Antilock Brake \(ABS\) - Standard Procedure](#)).

**3. (B32) VACUUM PRESSURE SENSOR SIGNAL CIRCUIT SHORTED TO VOLTAGE**

1. Turn ignition off to the lock position.

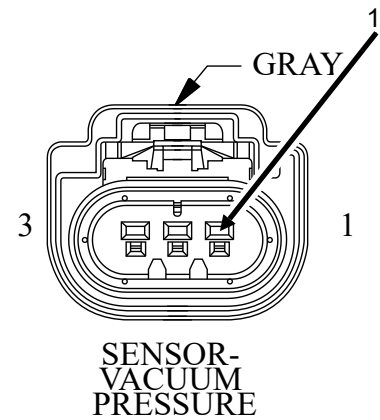
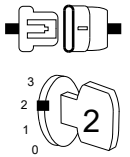
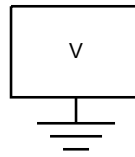

2878744

2. Disconnect the ABS Module harness connector.
3. Disconnect the Vacuum Pressure Sensor harness connector.
4. Ignition on, engine not running.
5. Measure the voltage between ground and the (B32) Vacuum Pressure Sensor Signal circuit at the Vacuum Pressure Sensor harness connector.

**Is there any voltage present?**

**Yes**

- Repair the (B32) Vacuum Pressure Sensor Signal circuit for a short to ground.
- Perform the ABS VERIFICATION TEST. ([Refer to 28 - DTC-Based Diagnostics/MODULE, Antilock Brake \(ABS\) - Standard Procedure](#)).

**No**

- Go To [4](#)

**4. (B32) VACUUM PRESSURE SENSOR SIGNAL CIRCUIT SHORTED TO GROUND**

- 
1. Turn ignition off to the lock position.

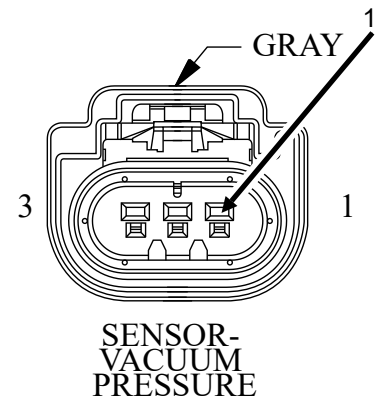
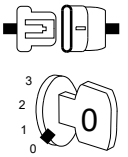
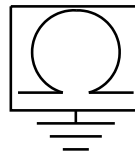

2878667

2. Disconnect the ABS Module harness connector.
3. Measure the resistance between ground and the (B32) Vacuum Pressure Sensor Signal circuit at the Vacuum Pressure Sensor harness connector.

**Is the resistance below 5.0 Ohms?**

**Yes**

- Repair the (B32) Vacuum Pressure Sensor Signal circuit for a short to ground.
- Perform ABS VERIFICATION TEST ([Refer to 28 - DTC-Based Diagnostics/MODULE, Antilock Brake \(ABS\) - Standard Procedure](#)).

**No**

- Go To [5](#)

**5. (B32) VACUUM PRESSURE SENSOR SIGNAL CIRCUIT OPEN OR HIGH RESISTANCE**

- 
1. Turn ignition off to the lock position.

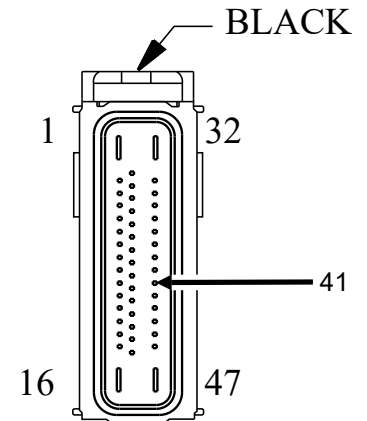
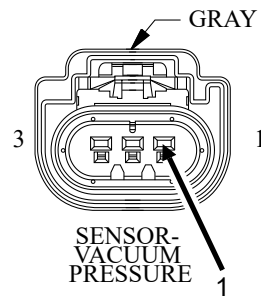
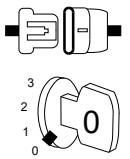
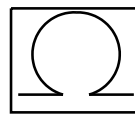

MODULE-  
ANTI-  
LOCK  
BRAKE  
SYSTEM

3172780

2. Disconnect the ABS Module harness connector.
3. Measure the resistance of the (B32) Vacuum Pressure Sensor Signal circuit between the Vacuum Pressure Sensor harness connector and the ABS Module harness connector.

**Is the resistance below 5.0 Ohms?**

**Yes**

- Go To [6](#)

**No**

- Repair the (B32) Vacuum Pressure Sensor Signal circuit for an open or high resistance.
- Perform the ABS VERIFICATION TEST. ([Refer to 28 - DTC-Based Diagnostics/MODULE, Antilock Brake \(ABS\) - Standard Procedure](#)).

**6. (B33) VACUUM PRESSURE SENSOR RETURN CIRCUIT OPEN OR HIGH RESISTANCE**

1. Turn ignition off to the lock position.

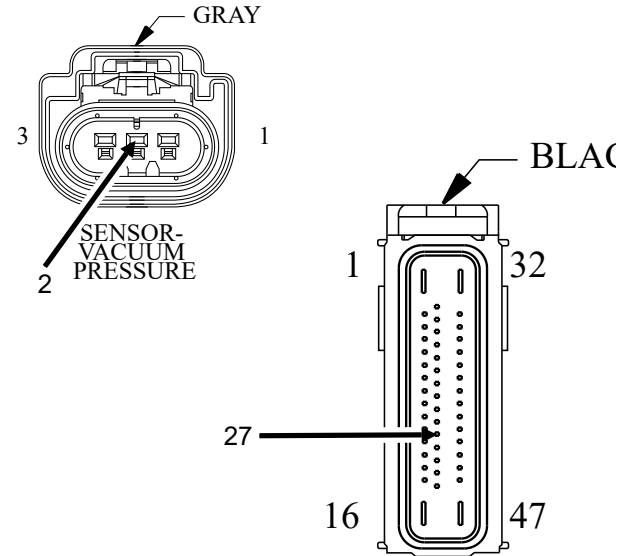
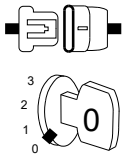
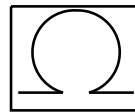

MODULE-  
ANTI-  
LOCK  
BRAKE  
SYSTEM

3172797

2. Measure the resistance of the (B33) Vacuum Pressure Sensor Return circuit between the Vacuum Pressure Sensor harness connector and the ABS Module harness connector.

**Is the resistance below 5.0 Ohms?**

**Yes**

- Go To [7](#)

**No**

- Repair the (B33) Vacuum Pressure Sensor Return circuit for an open or high resistance.
- Perform the ABS VERIFICATION TEST. ([Refer to 28 - DTC-Based Diagnostics/MODULE, Antilock Brake \(ABS\) - Standard Procedure](#)).

## 7. ANTI-LOCK BRAKE SYSTEM (ABS) MODULE

1. Turn the ignition off to the lock position.
2. Replace the Vacuum Pressure Sensor.
3. Perform the ABS VERIFICATION TEST. ([Refer to 28 - DTC-Based Diagnostics/MODULE, Antilock Brake \(ABS\) - Standard Procedure](#)).
4. With the scan tool, read the DTCs.

**Is the DTC still active?**

**Yes**

- Replace the Anti-lock Brake System (ABS) Module in accordance with the Service Information. ([Refer to 08 - Electrical/8E - Electronic Control Modules/MODULE, Anti-Lock Brake System - Removal](#)).
- Perform the ABS VERIFICATION TEST. ([Refer to 28 - DTC-Based Diagnostics/MODULE, Antilock Brake \(ABS\) - Standard Procedure](#)).

**No**

- Test complete.